



Digeal

Distribuzione Generi Alimentari

C A T A L O G O P R O D O T T I



Indice

INDICE

COLAZIONE

Brioches	pag. 006
Farciture	pag. 025
Pasticceria fresca	pag. 030
Caffetteria	pag. 033

PRANZO

Gastronomia fresca e surgelata	pag. 061
Paninochef	pag. 071
Apetizer, piadine e snack	pag. 044
Pane, pizze e focacce	pag. 052

TORTE E GELATO

Torte e monoporzioni	pag. 074
Gelato artigianale	pag. 080
Gelato Sammontana	pag. 094

PRODOTTI AMBIENTE

Barattolame	pag. 104
Monodose e salse	pag. 110
Pasta	pag. 113
Olio	pag. 115

BEVERAGE E RICORRENZE

Bevande analcoliche	pag. 116
Bevande alcoliche	pag. 122
Dolciumi	pag. 128
Materiale vario bar	pag. 133

FRESCHI

Salumi	pag. 137
Formaggi	pag. 149
Pastifici	pag. 173
Pesto e salse	pag. 182
Gastronomia	pag. 183
Yogurt	pag. 191
Lunga conservazione	pag. 195

SURGELATI

Carne	pag. 198
Pesce	pag. 201
Verdure	pag. 208

LA STORIA

40 quaranta

40 anni sono passati da quel lontano 1984.

I 40 anni dicono essere gli anni della consapevolezza.

Consapevolezza del percorso fatto fino ad oggi, degli obiettivi raggiunti, dei cambiamenti inevitabili, dell'impegno e della tenacia costanti, delle scelte talvolta audaci, coraggiose e delle molteplici soddisfazioni ottenute.

Continuiamo a guardare al futuro con immutato entusiasmo, certi che questo importante traguardo non sia un punto di arrivo, ma solo un nuovo punto di partenza.





1984

La Digeal apre i battenti nel lontano **1984**, quando tre giovani uomini, forti di un'esperienza nel settore della distribuzione dei gelati Sanson e mossi da uno **spirito d' avventura** e dal **desiderio di realizzarsi nella vita** decidono di mettersi in gioco; la posta è alta, c'è la coronazione di un sogno di mezzo. **Giovanni Bolognini, Giuseppe Locatelli e Oliviero Sirtoli**, cominciano la loro avventura con la distribuzione dei gelati GIS.



Nel **1988** la Digeal è ormai una realtà conosciuta nella bergamasca e decide così di spiccare il volo verso nuovi orizzonti, incorporando una **nuova linea alimentare: i surgelati "Brina"**. In questo modo può soddisfare tutte le esigenze dei consumatori; anche quelle più particolari e sofisticate.

1988

Nel **1992** nasce il laboratorio di produzione di gelato artigianale: **"Il gelato del Goloso"**, che verrà poi gestito dal figlio di Locatelli: Roberto, il quale, qualche anno più tardi, con l'uscita del padre dalla società entrerà a far parte della stessa.

1992

Nel **1997** inizia a distribuire i prodotti con il marchio storico **Tre Marie**.

1997

2003

Nel **2003** la Digeal cresce ulteriormente e dà avvio alla commercializzazione dei **gelati Sanson** nella bergamasca.



2005

Nel **2005** si vola verso nuove frontiere, vengono infatti introdotti i **prodotti freschi** nel mercato dell'azienda.

È il **2007** quando apre al pubblico lo **spaccio aziendale**, un negozio pensato per le famiglie con centinaia di prodotti freschi e surgelati.

L'anno successivo viene realizzato il nuovo laboratorio de **"Il gelato del Goloso"** nella nuova sede di Zanica.

2007

2011

Il **2011** è l'anno del caffè, la Digeal decide infatti di specializzarsi in un nuovo ramo, iniziando la distribuzione dell'italianissimo **Special Coffee**.

Nel **2012**, il marchio Sanson sparisce e lascia spazio a **Sammontana**, inizia così una nuova ed entusiasmante avventura.

2012

2013

Fine **2013** viene introdotta la nuova linea di **freschi e freschissimi** nello stesso periodo anche la nuova linea di **GM Piccoli**.

Con **40 anni di esperienza** e **oltre 4500 prodotti** commercializzati e **più di 5000 clienti** distribuiti su tutto il territorio bergamasco, la Digeal è oggi una realtà significativa nella provincia di Bergamo. **Tanti traguardi** e tante frontiere sono state raggiunte ma, il cassetto, è ancora colmo di sogni.

2024





PRONTO FORNO

DOLCI GESTI GENTILI



TRE MARIE
ANTICA MARCA

CROISSANT E SPECIALI

La colazione degli italiani al bar è cornetto e cappuccino.
Tre Marie propone l'offerta più ampia e completa di tutto il mercato.
Gamme differenti per grammatura e formato, strutture sfogliate o briosciate,
farcite semplici o ricercate, saranno in grado di soddisfare
le esigenze di tutti i Vostri clienti.



Senza Farcitura



600078 / 600116

3CHIC VUOTO / MIDI

con lucidatura

75 g. | 50 pz. | 170°/180° C | 20/25 min.
37 g. | 100 pz. | 170°/180° C | 15/20 min.

600006

GRANCROISSANT VUOTO

con zucchero cristallino

75 g. | 53 pz. | 170°/180° C | 20/25 min.

6468 **GLUTEN FREE****CROISSANT SENZA FARCITURA**

soffice morbido impasto

80 g. | 10 pz. | rinvenimento amb. 2 ore



600022 / 600021

EXTRA DRITTO / CURVO VUOTO

con zucchero cristallino

70 g. | 60 pz. | 170°/180° C | 20/25 min.



600023

5 CEREALI CURVO VUOTO

con zucchero di canna

65 g. | 50 pz. | 170°/180° C | 20/25 min.



600058 / 6482

VEGANO VUOTO / MIDI

con zucchero di canna

65 g. | 50 pz. | 170°/180° C | 20/25 min.
40 g. | 80 pz. | 170°/180° C | 15/20 min.

600120

CROISSANT AL BURRO

con pasta laminata al burro

55 g. | 75 pz. | 180/190° C | 20/25 min.



600124

MIGNON AL BURRO

con lucidatura

25 g. | 100 pz. | 170°/180° C | 15/20 min.



600046

PARIGINA

con granelle di zucchero

50 g. | 50 pz. | 170°/175° C | 20/25 min.



600076 / 600117

3CHIC ALBICOCCA / MIDI

con zucchero in granelle

90 g. | 50 pz. | 170°/180° C | 20/25 min.

42 g. | 80 pz. | 170°/180° C | 15/20 min.

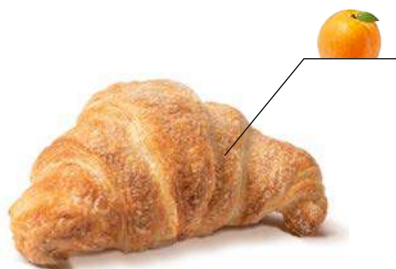

600029

GRANCROISSANT ALBICOCCA

con zucchero semolato

90 g. | 53 pz. | 170°/180° C | 20/25 min.

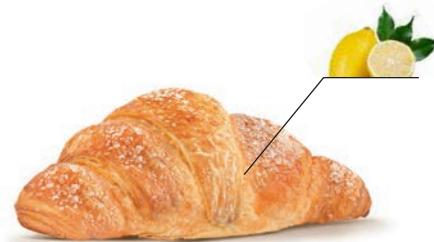

600082

3CHIC LIMONI DI SICILIA

con zucchero semolato

90 g. | 50 pz. | 170°/180° C | 20/25 min.

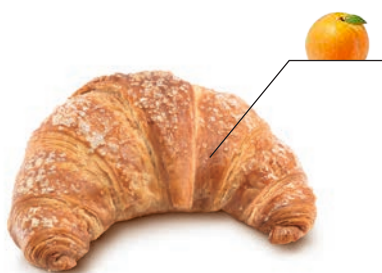

600027

EXTRA ALBICOCCA

con zucchero cristallino

80 g. | 50 pz. | 170°/180° C | 20/25 min.



600011

GRANFARCITO ALBICOCCA

con zucchero semolato

105 g. | 60 pz. | 170°/175° C | 25/30 min.

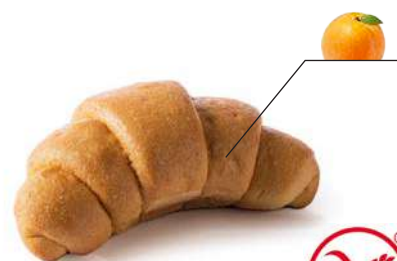

6469 **GLUTEN FREE**

CROISSANT ALBICOCCA

soffice morbido impasto

80 g. | 10 pz. | rinvenimento amb. 2 ore



600056

VEGANO ALBICOCCA

con semi di teff tostati

75 g. | 50 pz. | 170°/180° C | 20/25 min.

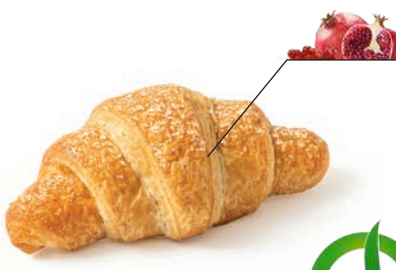

600059

VEGANO RIBES E MELOGRANO

con zucchero in di canna

75 g. | 50 pz. | 170°/180° C | 20/25 min.

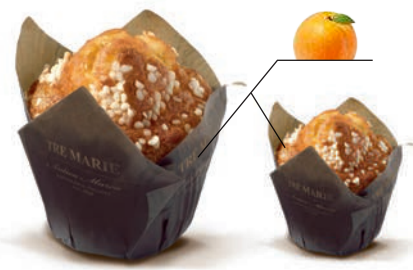

6487 / 6414

MUFFIN ALBICOCCA / BABY

con zucchero in superficie

90 g. | 30 pz. | rinvenimento amb. 3 ore

40 g. | 90 pz. | rinvenimento amb. 3 ore

Marmellate e Frutta

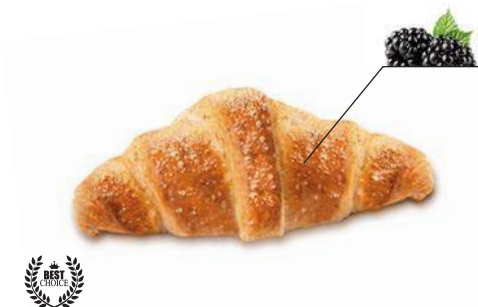

6132
3CHIC CEREALI ALLA MORA

con zucchero in di canna

90 g. | 50 pz. | 170°/180° C | 20/25 min.

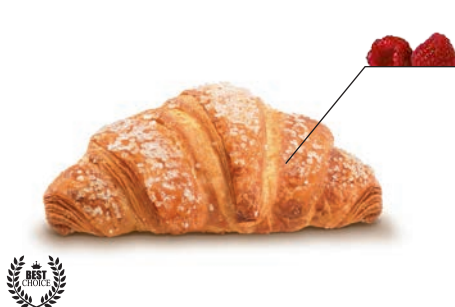

600075
3CHIC LAMPONE

con zucchero cristallino

90 g. | 50 pz. | 170°/180° C | 20/25 min.

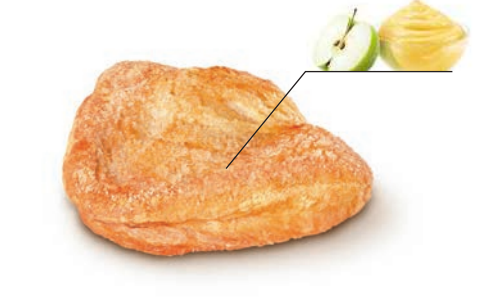

600068
MELANIA CREMA E MELA

con zucchero semolato

42 g. | 80 pz. | 170°/180° C | 15/20 min.

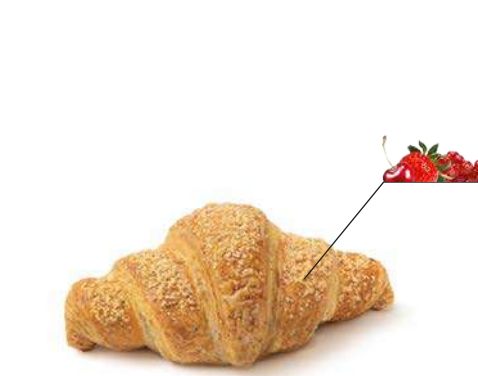

600063
5 CEREALI FRUTTI ROSSI

con zucchero di canna

75 g. | 50 pz. | 170°/180° C | 20/25 min.

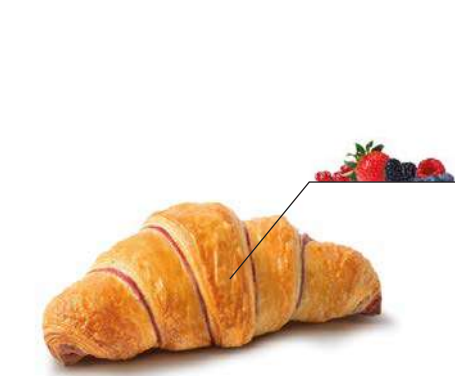

600034
RODRIGO BOSCO

con impasto bicolore

95 g. | 50 pz. | 170°/180° C | 20/25 min.

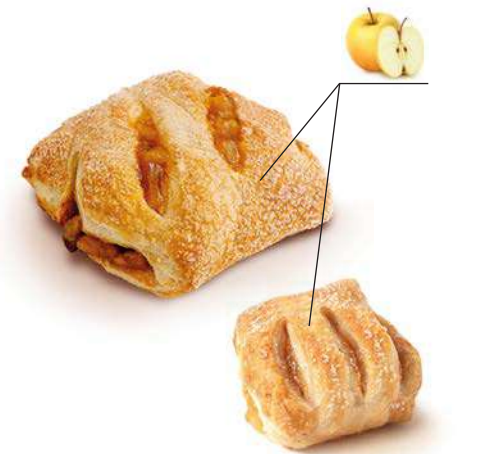

600047 / 600073
STRUDEL DI MELE / BABY

85 g. | 60 pz. | 180°/190° C | 20/25 min.
40 g. | 90 pz. | 170°/180° C | 20/25 min.

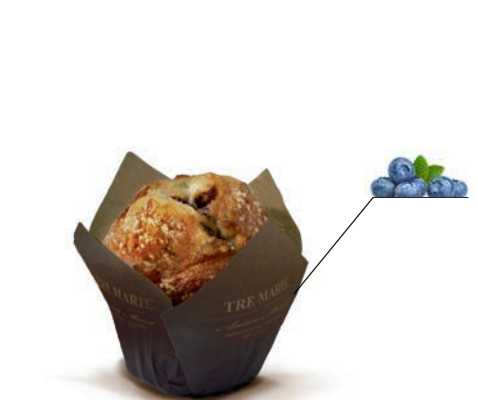

6488
MUFFIN MIRTILLI

con zucchero in superficie

90 g. | 30 pz. | rinvenimento amb. 3 ore

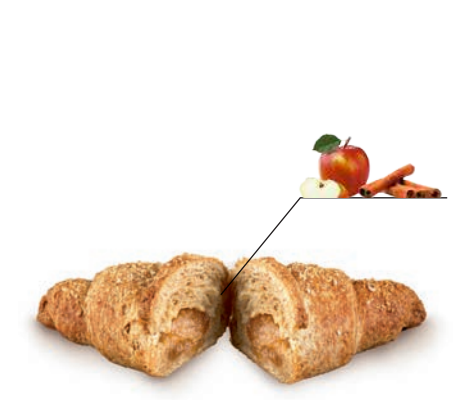

600062
INTEGRALE MELA E CANNELLA

con fiocchi di frumento integrale

80 g. | 50 pz. | 170°/180° C | 20/25 min.

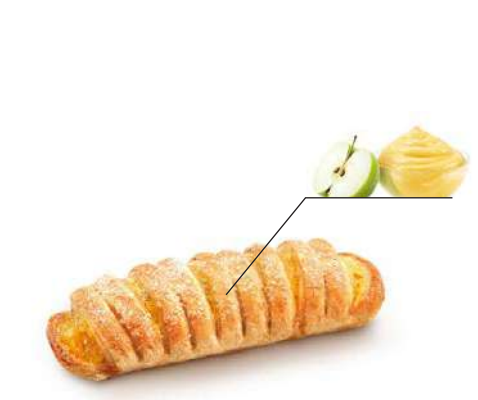

600044
IDILLIO CREMA E MELA

con zucchero semolato

80 g. | 60 pz. | 180°/190° C | 20/25 min.



600077

3CHIC NOCCIOLA CACAO

con scagliette di cioccolato

90 g. | 50 pz. | 170°/180° C | 20/25 min.

42 g. | 80 pz. | 170°/180° C | 15/20 min.



600037

GRANCROISSANT NOCC./CACAO

con scagliette di cioccolato

90 g. | 53 pz. | 170°/180° C | 20/25 min.



600054

EXTRA DARK FONDENTE

con scagliette di cioccolato

80 g. | 50 pz. | 170°/180° C | 20/25 min.



6446 / 6106

PAIN 3CHIC CIOCCOLATO / BABY

con gocce di cioccolato fondente

80 g. | 50 pz. | 170°/180° C | 20/25 min.

40 g. | 80 pz. | 170°/180° C | 20/25 min.

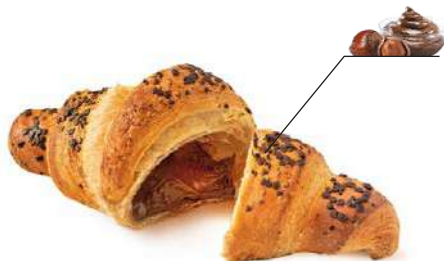

600015

GRANFARCITO NOCC. CACAO

con scagliette di cioccolato

105 g. | 60 pz. | 170°/175° C | 25/30 min.

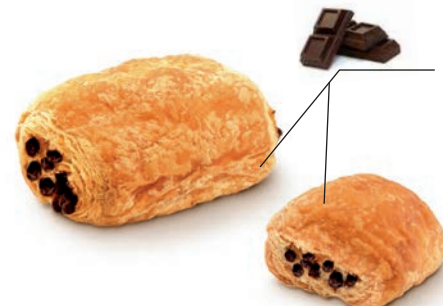

600040 / 600071

PAIN AU CHOCOLAT / BABY

con gocce di cioccolato fondente

70 g. | 106 pz. | 170°/180° C | 20/25 min.

40 g. | 90 pz. | 170°/180° C | 20/25 min.



6448

GHOTTO CIOCCOLATO

con gocce di cioccolato

90 g. | 50 pz. | 170°/180° C | 20/25 min.



600151

GHOTTO CIOCCOLATO E CREMA

con scagliette di cioccolato e zucc.

90 g. | 50 pz. | 170°/180° C | 20/25 min.



600014

GHOTTO TRE CIOCCOLATI

con scagliette di cioccolato

90 g. | 50 pz. | 170°/180° C | 20/25 min.

Cioccolato e Farciture Top

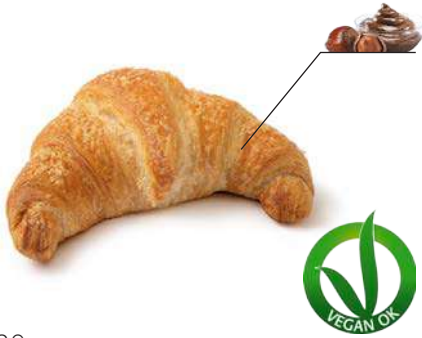

6429
VEGANO NOCCIOLA CACAO

con zucchero di canna

65 g. | 50 pz. | 170°/180° C | 20/25 min.

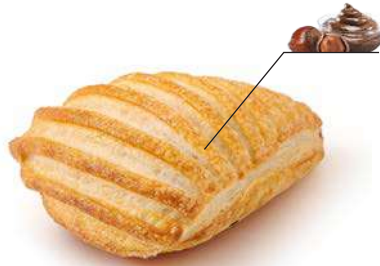

600049
RISVEGLIO NOCCIOLA CACAO

90 g. | 60 pz. | 170°/180° C | 20/25 min.



6486 / 6420
MUFFIN CACAO / BABY

con pezzi di cioccolato

90 g. | 30 pz. | rinvenimento amb. 3 ore
40 g. | 90 pz. | rinvenimento amb. 3 ore

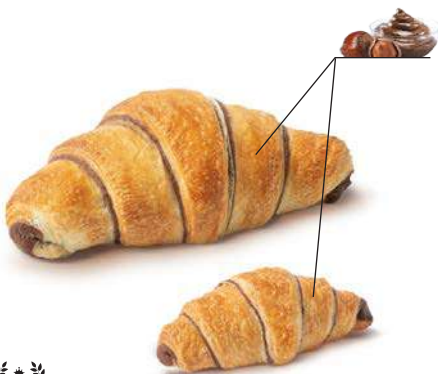

600033 / 600118
RODRIGO MORO / MIDI

95 g. | 50 pz. | 170°/180° C | 20/25 min.
45 g. | 80 pz. | 170°/180° C | 15/20 min.

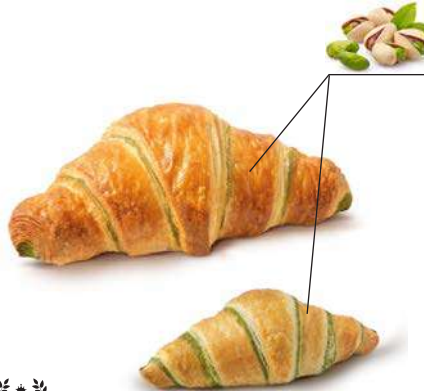

6415 / 6457
RODRIGO PISTACCHIO / MIDI

95 g. | 50 pz. | 170°/180° C | 20/25 min.
45 g. | 80 pz. | 170°/180° C | 15/20 min.

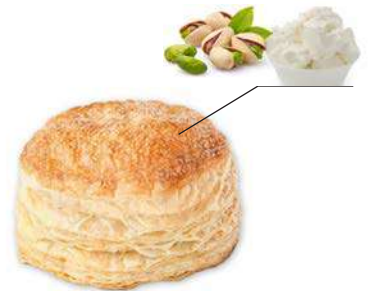

6503
**SFOGLIA D'ORO
PISTACCHIO E MASCARPONE**

90 g. | 50 pz. | 170°/180° C | 20/25 min.



600032
TRECCIA AL BURRO

con crema e pepite di cioccolato

80 g. | 50 pz. | 180°/190° C | 20/25 min.

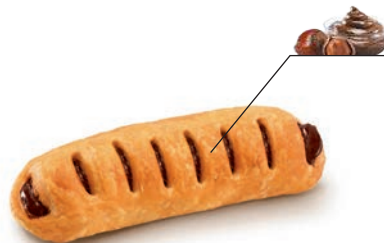

600038
CANNOLO NOCCIOLA CACAO

farcito dal primo all'ultimo morso

70 g. | 70 pz. | 170°/175° C | 18/20 min.



600008 / 600009 **GLUTEN FREE
MUFFIN CIOCCOLATO / MELA**

con gocce di ciocc. / pezzi di mela

75 g. | 8 pz. | rinvenimento amb. 3 ore
75 g. | 8 pz. | rinvenimento amb. 3 ore





600079 / 600152

3CHIC CREMA / MIDI

con codette di zucchero

90 g. | 50 pz. | 170°/180° C | 20/25 min.

42 g. | 80 pz. | 170°/180° C | 15/20 min.

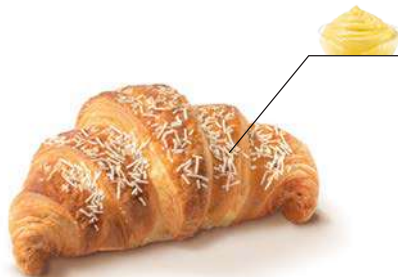

600028

GRANCROISSANT CREMA

con codette di zucchero

90 g. | 53 pz. | 170°/180° C | 20/25 min.

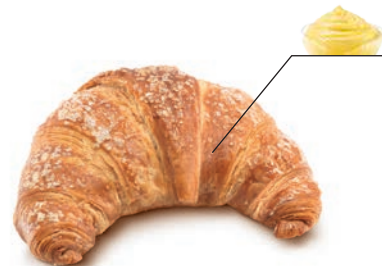

600019

EXTRA CREMA

con zucchero cristallino

80 g. | 50 pz. | 170°/180° C | 20/25 min.

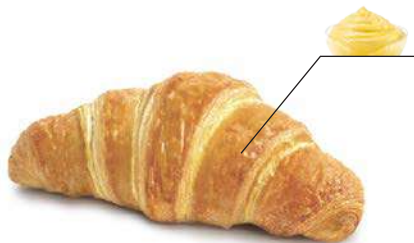

6074

RODRIGO BIONDO

95 g. | 50 pz. | 170°/180° C | 20/25 min.



600012

GRANFARCITO CREMA

con codette di zucchero

105 g. | 60 pz. | 170°/175° C | 25/30 min.



6402

GRANFARCITO CREMA AMARENA

con codette di zucchero

105 g. | 60 pz. | 170°/175° C | 25/30 min.

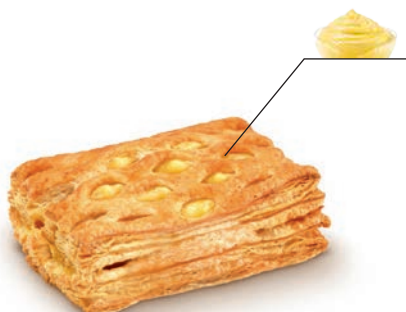

600036

GRECA CREMA CHANTILLY

con decorazione retinata

80 g. | 60 pz. | 190°/200° C | 20/25 min.



600039

TRECCIOLA CREMA AMARENA

con zucchero cristallino

85 g. | 70 pz. | 190°/200° C | 20/25 min.

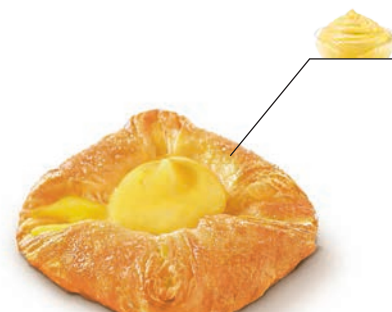

600042

DOLCE VITA CREMA

lucidata sulla superficie

87 g. | 40 pz. | 170°/175° C | 18/20 min.

Crema, Speciali e Mix

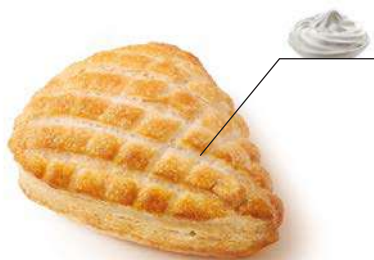

600050
RISVEGLIO FIORDILATTE

con zucchero semolato

105 g. | 60 pz. | 170°/175° C | 25/30 min.



600060
AURORA

con zucchero di canna

65 g. | 50 pz. | 170°/180° C | 20/25 min.



600016
MIGNON MIX

vuoto, albicocca, cioccolato

2.280 g. | 90 pz. | 170°/180° C | 15/20 min.



600123 / 600017
GIOSTRINA AL BURRO / BABY

con crema e uveta sultanina

95 g. | 50 pz. | 180°/190° C | 20/25 min.
33 g. | 100 pz. | 170°/180° C | 20/25 min.

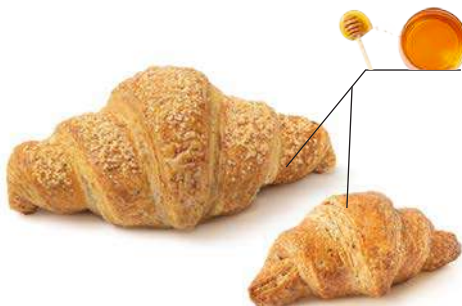

600055 / 600111
5 CEREALI MIELE

lucidato in superficie

75 g. | 50 pz. | 170°/180° C | 20/25 min.
45 g. | 80 pz. | 170°/180° C | 15/20 min.



600074
BABY MIX

albicocca, integrale fr. bosco, cioccolato, crema, strudel

40 g. | 125 pz. | 170°/180° C | 15/20 min.

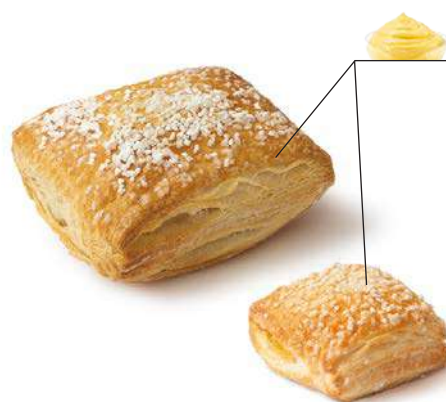

6447 / 6456
GHIOTTO CREMA / BABY

con perle di zucchero

95 g. | 50 pz. | 170°/180° C | 20/25 min.
40 g. | 90 pz. | 170°/180° C | 20/25 min.

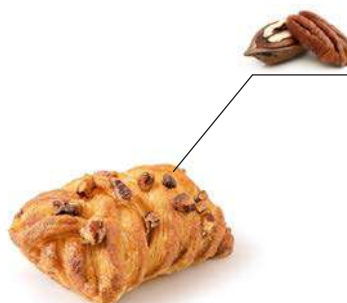

6485
BABY TRECCIA NOCI PECAN

con sciroppo d'acero

80 g. | 50 pz. | 170°/180° C | 20/25 min.



600067
FROLLE MIX

già cotte

2.445 g. | 40 pz. | rinvenimento amb. 3 ore



600069 / 600052

DONUTS MIX / BABY

cartone assortito Donuts semplici

57 g. | 36 pz. | rinvenimento amb. 3 ore
21 g. | 90 pz. | rinvenimento amb. 3 ore



600070

DONUTS FARCITI

cartone assortito Donuts farciti

68 g. | 36 pz. | rinvenimento amb. 3 ore



600010

KRAPFEN SENZA FARCITURA

con bustina di zucchero a velo

70 g. | 24 pz. | rinvenimento amb. 3 ore

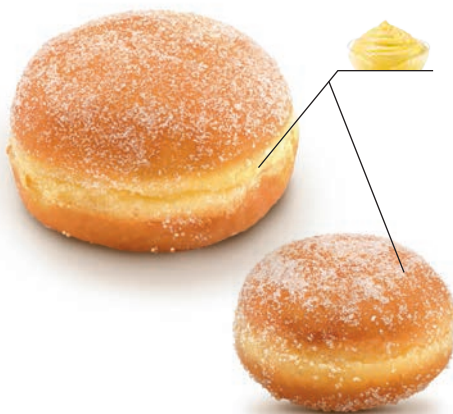

600080 / 600131

KRAPFEN CREMA / BABY

con abbondante farcitura alla crema

85 g. | 24 pz. | rinvenimento amb. 3 ore
25 g. | 100 pz. | rinvenimento amb. 3 ore



600121 / 600132

CIAMBELLA / BABY

con zucchero semolato

49 g. | 40 pz. | rinvenimento amb. 3 ore
25 g. | 100 pz. | rinvenimento amb. 3 ore

Salati



600024

PANCROISSANT SALATO

con lucidatura

70 g. | 60 pz. | 170°/180° C | 20/25 min.



600026

PANCROISSANT ARRICCHITO

semi di lino, lino giallo e sesamo
nell'impasto e sulla superficie

65 g. | 60 pz. | 170°/180° C | 20/25 min.



600119

MIGNON SALATO ARRICCHITO

arricchito da semi di papavero,
con lino sesamo e lino giallo

25 g. | 100 pz. | 170°/180° C | 15/20 min.



6461
FAGOTTINO CREMA

con crema pasticcera

73 g. | 6 pz. X6 buste | 180° C | 25 min.



6442
FAGOTTINO CIOCCOLATO

con gocce di cioccolato fondente

65 g. | 6 pz. X6 buste | 180° C | 25 min.



6458
CORNETTO SEMPLICE

con lievito madre

55 g. | 6 pz. X6 buste | 180° C | 25 min.



6459
CORNETTO ALL'ALBICOCCA

con confettura extra di albicocche

62 g. | 6 pz. X6 buste | 180° C | 25 min.



6460
CORNETTO 5 CEREALI

con farcitura ai frutti di bosco

65 g. | 6 pz. X6 buste | 180° C | 25 min.



6481
RODRIGO PISTACCHIO

farcito da punta a punta

45 g. | 5 pz. X6 buste | 180° C | 25 min.



6480
RODRIGO NOCCIOLA CACAO

farcito da punta a punta

57 g. | 6 pz. X6 buste | 180° C | 25 min.



PRONTO FORNO



SFOGLIE GM PICCOLI

Grazie alla cura per la qualità, all'utilizzo di ingredienti selezionati e all'impiego di personale esperto, **GM Piccoli** punta alla creazione di prodotti in grado di testimoniare l'attenzione per l'esperienza e la tradizione, unite al desiderio di rinnovamento.

Le Speciali Sfoglie® sono prodotti di pasta sfoglia dal design innovativo ed esclusivo, preparati con cura, passione ed ingredienti selezionati.

"Le Speciali Sfoglie" quali Perla™, Alba di Sfoglia, Volo di Sfoglia, Intreccio Rondò, Foglia di Sfoglia, Diamante di Sfoglia e Zaffiro sono
MODELLI REGISTRATI - RIPRODUZIONE RISERVATA REGISTERED DESIGN - REPRODUCTION RESERVED





GM104020
PERLA CREMA LATTE PANNA

90 g. | 60 pz. | 170°/180° C | 15/20 min.



GM104035
PERLA NOCCIOLA

85 g. | 60 pz. | 170°/180° C | 15/20 min.



GM104030L
PERLA CIOCCOLATO FOND.

85 g. | 48 pz. | 170°/180° C | 15/20 min.



GM104074
FOGLIA MELA E CREMA

95 g. | 48 pz. | 170°/180° C | 15/20 min.



GM101175
DIAMANTE CREMA PASTICCERA

54 g. | 48 pz. | 170°/180° C | 15/20 min.



GM101302L
VOLO CREMA CATALANA

90 g. | 24 pz. | 170°/180° C | 20/25 min.



GM100284N
ZAFFIRO CREMA PASTICCERA

95 g. | 60 pz. | 170°/180° C | 20/25 min.



GM100282N
ZAFFIRO FRUTTI ROSSI

90 g. | 60 pz. | 170°/180° C | 20/25 min.



GM100274N
ZAFFIRO NOCCIOLA

95 g. | 48 pz. | 170°/180° C | 20/25 min.



GM104007A
KIT 6 SPECIALITÀ SFOGLIA

85-90 g. | 36 pz. | 170°/180° C | 20/25 min.



GM100143P
SFOGLIATINA PERA E CIOCC.

95 g. | 60 pz. | 170°/180° C | 20/25 min.



GM104080
CONCHIGLIA LATTE PANNA

85 g. | 60 pz. | 170°/180° C | 20/25 min.



GM100274
INTRECCIO RONDÒ NOCCIOLA

90 g. | 60 pz. | 170°/180° C | 20/25 min.



GM100278R
INTRECCIO RONDÒ FRUTTI ROSSI

90 g. | 60 pz. | 170°/180° C | 20/25 min.



GM104081
CONCHIGLIA NOCCIOLA

85 g. | 60 pz. | 170°/180° C | 20/25 min.



GM100900
VEGAN 7 FRUITS

70 g. | 60 pz. | 170°/180° C | 20/25 min.



GM100901
VEGAN NOCCIOLA FAR. FARRO

80 g. | 60 pz. | 170°/180° C | 20/25 min.



PRONTO FORNO



Altri Marchi
ALTRI MARCHI





BC002SG
CROISSANT VUOTO BURMIER

70 g. | 60 pz. | 170° C | 20/25 min.



BC003SG
CROISS. ALBICOCCA BURMIER

85 g. | 60 pz. | 170° C | 20/25 min.



BC004SG
CROISS. CREMA BURMIER

85 g. | 60 pz. | 170° C | 20/25 min.



BC005SG
CROISS. CIOCK BURMIER

85 g. | 60 pz. | 170° C | 20/25 min.



C0147
CROISS. CON BURRO VUOTO

75 g. | 60 pz. | 170° | 20/25 min.



SC18390 / SC1839
POLACCA DA LIEVITARE / PRONTO FORNO

75 g. | 100 pz. / 80 g. | 50 pz.



C0048
CROISS. CON BURRO ALBICOCCA

90 g. | 60 pz. | 170°C | 20/25 min.



C0049
CROISS. CON BURRO CIOCK

90 g. | 60 pz. | 170°C | 20/25 min.



C0050
CROISS. CON BURRO CREMA

90 g. | 60 pz. | 170°C | 20/25 min.



600136

CORNETTO DIRITTO VUOTO

65 g. | 75 pz. | 170°/180° C | 20/25 min.



600139

GRAN CROISSANT CREMA

90 g. | 60 pz. | 170°/180° C | 20/25 min.



600122

PANCIOKO

65 g. | 80 pz. | 170°/180° C | 20/25 min.



DOR18070007

TRECCIA MAXI NOCI PECAN

95 g. | 48 pz. | 170°/180° C | 20/25 min.



DOR18110000

CORONA ALLA MELA

97 g. | 48 pz. | 170°/180° C | 20/25 min.



600030

PASTICCIOTTO CREMA

110 g. | 30 pz. | 170°/180° C | 20/25 min.



LIG090

DIRITTO VUOTO VEGANO

60 g. | 60 pz. | 170°/180° C | 20/25 min.



LIG091

CURVO ALBICOCCA VEG.

70 g. | 52 pz. | 170°/180° C | 20/25 min.



600025

PASTIC. CREMA/CIOCCOLATO

110 g. | 30 pz. | 170°/180° C | 20/25 min.



LIG090

DIRITTO VUOTO VEGANO

60 g. | 60 pz. | 170°/180° C | 20/25 min.

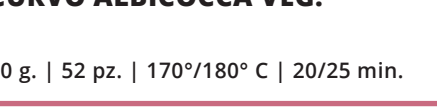

LIG091

CURVO ALBICOCCA VEG.

70 g. | 52 pz. | 170°/180° C | 20/25 min.



600048

PASTIC. CREMA/AMARENA

110 g. | 30 pz. | 170°/180° C | 20/25 min.



PAST6850
SBRODOLONE

100 g. | 10 pz.
rinvenimento amb. 2 ore



600201
KRAPFEN NEUTRO

60 g. | 36 pz.
rinvenimento amb. 2 ore



600202
KRAPFEN CREMA

80 g. | 36 pz.
rinvenimento amb. 2 ore



600203
KRAPFEN MARMELLATA

80 g. | 36 pz.
rinvenimento amb. 2 ore



600205
**KRAPFEN MIGNON
NEUTRO**

15 g. | 120 pz.
rinvenimento amb. 2 ore



600206
**KRAPFEN MIGNON
CREMA**

25g. | 120 pz.
rinvenimento amb. 2 ore



600207
**KRAPFEN MIGNON
MARMELLATA**

25g. | 120 pz.
rinvenimento amb. 2 ore



600208
**KRAPFEN MIGNON
CIOCCOLATO**

25 g. | 120 pz. | scongelamen-
to temp. ambiente 2 ore



600081
CIAMBELLA

60 g. | 40 pz.
rinvenimento amb. 2 ore



600204
CIAMBELLINA

20 g. | 120 pz.
rinvenimento amb. 2 ore



600200
CIAMBELLA CREMA

90 g. | 36 pz.
rinvenimento amb. 2 ore



54107
DONUT MARS

57 g. | 36 pz.
rinvenimento amb. 2 ore



131
**INTRIKO
CIOCCOLATO**

70 g. | 30 pz.
rinvenimento amb. 2 ore



132
**INTRIKO
CREMA**

70 g. | 30 pz.
rinvenimento amb. 2 ore



140
**INTRIKO
PISTACCHIO**

70 g. | 30 pz.
rinvenimento amb. 2 ore



141D
**INTRIKO
CARAMELLO**

70 g. | 30 pz.
rinvenimento amb. 2 ore

DA LIEVITARE



TRE MARIE
ANTICA MARCA

Professional
LINEA PROFESSIONAL

I grandi classici dell'assortimento **Tre Marie** nella versione da lievitare, mantengono intatta la loro artigianalità nell'aspetto e nel gusto. Un prodotto professionale al servizio dei professionisti!



600125 | 63 g. | 182 pz.
DIRITTO VUOTO DA LIEVITARE

600126 | 63 g. | 170 pz.
CURVO VUOTO DA LIEVITARE

170°/180° C | 15/20 min.



600128 | 70 g. | 170 pz.
CURVO ALBICOCCA DA LIEV.

600127 | 70 g. | 170 pz.
DIRITTO ALBICOCCA DA LIEV.

170°/180° C | 15/20 min.



600158 | 85 g. | 110 pz.
MAXI VUOTO DA LIEVITARE

170°/180° C | 15/20 min.



DA LIEVITARE



Professional LINEA PROFESSIONAL

I grandi classici dell'assortimento **San Giorgio** nella versione da lievitare,
La cura richiesta nella preparazione e l'attesa
dei tempi giusti sono ripagate dalla genuinità del sapore e dei profumi.



600145
CORNETTO VUOTO

80 g. | 100 pz. | 175°/180° C | 15/17 min.



600140
CORNETTO ALBICOCCA

85 g. | 100 pz. | 175°/180° C | 15/17 min.



600141
CORNETTO CREMA

85 g. | 100 pz. | 175°/180° C | 15/17 min.

DISPENSER EROGATORI

Squeezita
made in italy*Farciture*
FARCITURE

Opportunità tutte da farcire. È ideale per bar, locali e postazioni street food.
È in grado di erogare cioccolato, creme, marmellate e miele per una proposta dolce.
Guarnire o farcire le tue preparazioni non è mai stato così facile.





**È POSSIBILE
REGOLARE IL
DOSAGGIO
10-15 GR**



**È ideale per bar, locali e postazioni street food.
È in grado di erogare cioccolato, creme,
marmellate e miele per una proposta dolce.**



è possibile
realizzare
**farciture
combinare**

**Guarnire o farcire le tue preparazioni
non è mai stato così facile.**



DESIGN

Il design studiato appositamente per attirare l'attenzione del cliente.
Possibilità di creare moduli personalizzati grazie al sistema di fissaggio "stile puzzle".

EROGAZIONE SEMPLICE

I dispenser erogano creme ad alta viscosità, confetture a pezzi fino a 7 mm e crunchy.
Possibilità di regolazione del dosaggio.

NESSUNO SCARTO

Grazie alla farcitura on demand.

ALTI MARGINI

Upselling grazie alla personalizzazione dei prodotti.

CREATIVITÀ E GUSTO

Sfiziose farciture tutte da gustare.

PRATICITÀ

Beccuccio studiato per la farcitura interna del prodotto.

VEGAN FRIENDLY

Disponibili referenze vegan.

MADE IN ITALY

Tutte le creme spalmabili sono prodotte al 100% in Italia e con materie prime selezionate.
24 mesi di shelf life garantita.

PRATICO E IGIENICO

Componenti adatti al contatto con gli alimenti, di facile pulizia e smontaggio.

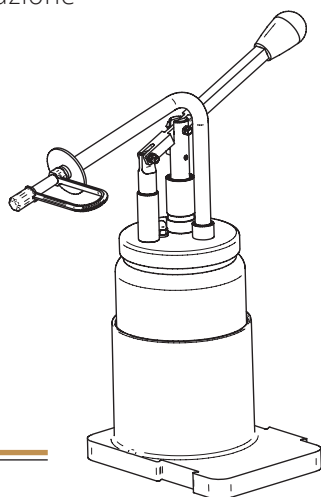

SQ139
DISPENSER COMPLETO

1 pz. + base | regolazione 10/15 g.



CARATTERISTICHE TECNICHE

Peso Kg	1,85
Profondità mm	195
Larghezza mm	147/405
Altezza mm	420
Capacità kg	2



SQ416
SQUEEZITA PISTACCHIO

2 Kg.



SQ418
SQUEEZITA BIANCA NOCCIOLA

2 Kg.



SQ417
SQUEEZITA CIOCC. FONDENTE

2 Kg.



SQ428
SQUEEZITA GRANCREMA NOCC.

2 Kg.



SQ013
SQUEEZITA CIOCC. BIANCA

2 Kg.



SQ001
SQUEEZITA CARMELLO SALATO

2 Kg.



SQ419
SQUEEZITA ALBICOCCA

2 Kg.



SQ420
SQUEEZITA FRUTTI DI BOSCO

2 Kg.



SQ012
SQUEEZITA ARANCIA

2 Kg.



SQ003
SQUEEZITA COCCO

2 Kg.



SQ014
SQUEEZITA CHOCO NUTS CRUNCHY

2 Kg.



SQ015
SQUEEZITA CHOCO BISCUIT CRUNCHY

2 Kg.



PC398
SECCHIELLO CREMA FRESCA

5 Kg.



MONOPORZIONI

Pasticceria PASTICCERIA

Pasticceria artigianale con vendita all'ingrosso, un'espressione che è tutto un programma e che suggerisce bontà e piacere.

Con una produzione assolutamente artigianale l'eccellenza è garantita, sia per quanto riguarda le materie prime di alta qualità (tutto burro, senza conservanti né coloranti), che per la metodologia di preparazione tutta manuale.

Genuinità, esperienza e tanta cura per deliziare il palato dei nostri golosi di qualità.





600260
CANNOLO MAXI CREMA

10 pz. | Durata prodotto 30 gg.



600261
CANNOLO MAXI GIANDUIA

10 pz. | Durata prodotto 30 gg.



600263
PARIGINA ALBICOCCA

10 pz. | Durata prodotto 30 gg.



600269
TORTA DIPLOMATICA

10 pz. | Durata prodotto 30 gg.



600270
TORTA DELIZIA

10 pz. | Durata prodotto 30 gg.



600274
FIAMMA

15 pz. | Durata prodotto 30 gg.



600272
PESCHE

10 pz. | Durata prodotto 30 gg.



600277
CANNONCINO CREMA

1 kg. | Durata prodotto 30 gg.



600276
CANNONCINO GIANDUIA

1 kg. | Durata prodotto 30 gg.



PA0007
**BISCOTTI DOPPI
LIMONE**

1 Kg.



PA0008
**BISCOTTI DOPPI
ALBICOCCA**

1 Kg.



PA0009
**BISCOTTI DOPPI
NOCCIOLA**

1 Kg.



PA00010
**BISCOTTI DOPPI
CIOCCOLATO**

1 Kg.



200799
DOBLONI ASSORTITI

24 pz. | Durata prodotto 30 gg.



CA0001
CANNONCINI VUOTI

12 g. | 50 pz. | Durata prodotto 30 gg.



PA0011
LINGUE DI GATTO

1 kg. | Durata prodotto 30 gg.



TA0001
**TARTELLE MIX
CIOCCOLATO**

9 pz. | Durata prodotto 30 gg.



TA0002
**MINI TARTELLINE MIX
CIOCCOLATO**

28g. | 35 pz. | Durata 30 gg.



GIMI116
**BISCOTTERIA
ASSORTITA MIGNON**

1 kg. | Durata prodotto 30 gg.



GIMI103
**GIRELLE
BLACK&WHITE**

1 kg. | 75 pz. | Durata 30 gg.



GIMI110
**BACI DI DAMA
BIANCHI**

1 kg. | 75 pz. | Durata 30 gg.



GIMI119
CANESTRELLI

1 kg. | 62 pz. | Durata 30 gg.



GIMI215
**APOLLINO MIX
CON COPERTURA**

1,5 kg. | 40 pz. | Durata 30 gg.



GIMI508
**CROSTATINE
ALBICOCCA GRANDE**

9 pz. | Durata 30 gg.



GIMI570 / GIMI574
**ESSE MEDIE LISCE
ESSE MEDIE CIOKKO**

32 pz. | Durata 30 gg.



GIMI520
**CROSTATINE MEDIE
MARMELLATA MIX**

32 pz. | Durata 30 gg.



GIMI590
**MISTO FROLLE
ESSE/OCCHI MIX MEDI**

32 pz. | Durata 30 gg.



GIMI592
**OCCHI DI BUE
MIX MEDI**

32 pz. | Durata 30 gg.

CAFFÈ



SpecialCoffee®
...passione per il caffè

Passione per il caffè
PASSIONE PER IL CAFFÈ

Qualità, alta e costante, passione, tradizione,
responsabilità ed innovazione sono gli ingredienti della nostra ricetta segreta.
Dal 1999 SpecialCoffee è aroma,
gusto e crema del perfetto espresso "made in Italy".
Lasciatevi emozionare...



FROM THE BEAN TO THE CUP

Tostatura lenta e raffreddamento ad aria.

Un espresso perfetto, naturalmente!

Anche se quella del caffè non è una scienza esatta, solo quando hai la passione e la conoscenza, potrai offrire un caffè eccellente!



Dal 1999 le miscele di caffè SpecialCoffee hanno una ricetta segreta fatta di:

- attenta ricerca e **selezione** delle materie prime
- **importazione** dei migliori caffè direttamente dai Paesi di origine
- **miscela**
- **tostatura lenta** come insegna la migliore tradizione
- **raffreddamento** naturale **ad aria**
- **confezionamento** con packaging innovativi
- passione per il caffè



980016 • GRAN SELEZIONE 3 KG.

Miscela di caffè in grani per macchine espresso bar dal gusto dolce, fortemente aromatico e profumato, con note fruttate e floreali, composta da un'alta percentuale di pregiati Arabica brasiliani e centroamericani, bilanciati da Robusta provenienti da piantagioni selezionate dei migliori caffè asiatici.

Caffè in grani per macchine espresso bar per rendere il tuo locale esclusivo. Barattolo con adattatore da 3 Kg.



980001 • MORNING ARABICA 1 KG.

Miscela di caffè in grani dal gusto intenso e aroma persistente, composta dai migliori Arabica brasiliani e centroamericani con pregiati Robusta asiatici e africani.

Caffè in grani per macchine espresso bar, perfetto per il cappuccino. Confezionato in busta da 1 Kg.



980002 • GRAN CREMA 1 KG.

Miscela di caffè in grani per macchine espresso dal gusto pieno e aroma intenso, composta dai migliori Arabica brasiliani e centroamericani con pregiati Robusta asiatici e africani.

Caffè in grani per macchine espresso bar o da macinare a casa. Confezionato in busta da 1 Kg.



980004 • CAFFÈ DECAFFEINATO 80 CAPSULE 500 G.

Caffè decaffeinato in polvere per macchine espresso bar. Confezionato in buste monodose.





X0001
CIALDE ESPRESSO 150 PZ.

Miscela dal gusto rotondo e aroma pieno, composta da una percentuale equilibrata di Arabica e Robusta provenienti da piantagioni selezionate dei migliori caffè brasiliani, centroamericani, asiatici.

Caffè in cialde ESE 44mm compatibili con tutte le macchine Easy Serving Espresso. Confezione singola in atmosfera protettiva da 7g.



X0006
CIALDE BI ORZO 50 PZ.

Dal gusto simile al caffè classico e dalla consistenza molto densa e cremosa, l'Espresso d'orzo rappresenta il giusto compromesso per chi non ama assumere caffeina.

Caffè in cialde ESE 44mm compatibili con tutte le macchine Easy Serving Espresso. Confezione singola in atmosfera protettiva da 7g.



X0005
CIALDE DECAFFEINATO 50 PZ.

Una piacevole consistenza cremosa ed una delicatezza, pensati per gli appassionati del caffè che preferiscono rinunciare alla caffeina, ma non al piacere del gusto e dell'aroma di un caffè di notevole qualità.

Caffè in cialde ESE 44mm compatibili con tutte le macchine Easy Serving Espresso. Confezione singola in atmosfera protettiva da 7g.

ZUCCHERO E DOLCIFICANTI



980020
ZUCCHERO IN BUSTINA

Cartone da 10 kg. bustine personalizzate



980023
ZUCCHERO DI CANNA IN BUSTINA

Cartone da 5 kg. bustine personalizzate



980025
DOLCIFICANTE

Dispenser da 310 bustine



932025
MIELE MARSUPIO MONO.

200x6 gr.



907033
FRUTTOSIO MARSUPIO

200x5 gr.



980044
TAZZA ESPRESSO VETRO
70 cc con piattino



X0100
PALETTE INCARTATE
95 mm



980046
TAZZA ESPRESSO
70 cc con piattino



980047
TAZZA CAPPUCCINO
220 cc con piattino



980048
BICCHIERE VETRO LATTE
300 cc



980057
LATTIERA
75 cc



980058
MUG
320 cc



980045
PORTATOVAGLIOLI MARRONE
pz. 1



980049
PORTAZUCCHERO
pz. 1



980042
TOVAGLIOLINI
pz. 500



980056
GREMBIULE CORTO MARRONE
pz. 1



980054
GREMBIULE CORTO NERO
pz. 1



980055
GREMBIULE LUNGO
pz. 1



980032
PORTAFILTRO PER CAPSULE

1 pz.



980035
PRESSINO DINAMOMETRICO

adj base inox



980034
FILTRO ADDOLCITORE BIEPI

1 pz.



980053
OROLOGIO DA MURO

1 pz.



POP004
RENDIRESTO

1 pz.



980043
TAPPETINO NERO SILICONE

1 pz.



980060
D-STOVL DETERGENTE

6 kg



980061
D-BRILL BRILLANTANTE

5 kg



980063
SALE PASTIGLIE IDROSAL

25 kg.



980084
**PULIZIA
LANCIA VAPORE**

1 lt.



980074
**DETERGENTE
MACCHINA CAFFÈ**

barattolo



980077
**PULITORE
MACINACAFFÈ**

1 pz.



980080
**DECALCIFICANTE
BOLLITORI**

1 pz.

ALTRI PRODOTTI

Ciocolatate e The

CIOCCOLATE E THE



980102
CIOCCOLATA CLASSICA

25 monodosi da 30 gr.



980101
CIOCCOLATA FONDENTE

25 monodosi da 30 gr.



980100
CIOCCOLATA BIANCA

25 monodosi da 30 gr.

* disponibili altri gusti su ordinazione

980097
THE NERO CLASSICO CEYLON

15 filtri





ALTRI PRODOTTI

ORZO E GINSENG

Dispenser automatico di bevande calde per il bar.

Due gruppi di miscelazione.

Quattro dosi programmabili da pulsantiera.

Controllo elettronico della temperatura.

Sensore di livello acqua elettronico.

Controllo crediti con smartcard.

Filtro anticalcare in resina con segnalazione fine autonomia.

Sistema di aspirazione vapori e lavaggio mixer automatico.



980090

CAFFÈ GINSENG SOLUBILE BUSTA 500 G.

Una piacevole consistenza cremosa ed una delicatezza, pensati per gli appassionati del caffè che preferiscono rinunciare alla caffeina, ma non al piacere del gusto e dell'aroma di un caffè di notevole qualità.

Confezione da 500 gr. in atmosfera protettiva



980091

CAFFÈ ORZO SOLUBILE BUSTA 250 G.

Dal gusto simile al caffè classico e dalla consistenza molto densa e cremosa, l'Espresso d'orzo rappresenta il giusto compromesso per chi non ama assumere caffeina..

Confezione da 250 gr. in atmosfera protettiva



ALTRI PRODOTTI

Fresco, Senza Lattosato e Soya

LATTE, DELATTOSATO E SOYA



137000
LATTE FRESCO (20GG) INTERO

1 litro | con tappo

FLORA01
LATTE DI SOIA ALPRO 1 L.

1 litro | con tappo

FL3553
LATTE ALTA DIGERIBILITÀ

1 litro | con tappo



ATTREZZATURE

Tutto l'occorrente



Macchine da caffè per bar

Per il bar. la macchina giusta al posto giusto.

Macchine per caffè espresso robuste ed affidabili, equipaggiate con un microprocessore che permette una facile programmazione delle dosi di caffè.

A2 e A3: 2 lance vapore, 1 lancia acqua calda multidirezionale in acciaio inox.





Addolcitore acqua a sale

I vantaggi derivati dall'uso di acqua addolcita sono concreti e tangibili. Lo forniamo per rispondere alle esigenze di coloro che utilizzano attrezzature per bar, grandi cucine, ristoranti, alberghi e produttori o commercianti di macchine da caffè e torrefattori.

Macinadosatore istantaneo automatico

Macine piane \varnothing 64mm.

Macinatura istantanea: macina la dose direttamente nel porta filtro all'atto della richiesta. Regolazione elettronica della dose.

Dose singola e dose doppia regolabili indipendentemente.

Regolazione macinatura micrometrica continua con visualizzazione valore a display. Micro sicurezza sgancio tramoggia.

Carrozzeria pressofusa verniciata.



Macchine a cialde professionale 2 gruppi

Grazie alla tecnologia del monodose rende possibile offrire prodotti professionali che non necessitano del macinino, consentendo di offrire un ottimo prodotto in modo semplice e con risultati costanti nel tempo.

Lavatazzine

Struttura interamente costruita in acciaio inox.

Scarico tradizionale con troppopieno. Predisposizione pompa di scarico, su richiesta per tutti i modelli.

Dosatore peristatico temporizzato di brillantante di serie.

Predisposizione per collegamento dosatore detersivo.

Dotazione standard 2 cesti, portacucchiaini, canna di scarico.

Accesso frontale a tutti i componenti.





SURGELATI

Appetizer

APPETIZER

L'assortimento appetizer di Digeal si amplia con l'arrivo di nuove referenze, sviluppate con fornitori certificati seguendo le ricette più tradizionali.

I prodotti sono precotti e si preparano in pochi minuti sia in forno che in friggitrice.

Buoni, gustosi e pratici, ideali per aperitivi, antipasti e finger food!

Gli Appetizer surgelati sono il prodotto ideale per offrire ai tuoi clienti un aperitivo sfizioso che saprà regalare momenti di piacevole convivialità.





FIO0004

OLIVE ASCOLANE | 1000 gr.

FIO7504

OLIVE ASC. TARTUFO | 1000 gr.

FIO9004

CAPRESE NUGGET | 1000 gr.

FIO1804

MOZZARELLINE PANATE | 1000 gr.

FIO7404

MOZZ. PANATE TARTUFO | 1000 gr.

FIO1604

MOZZARELLINE STICK | 1000 gr.

FIO1104

BLUE CHEESE STICK | 1000 gr.

FIO2704

MAC & CHEESE | 1000 gr.

3604

CACIO PEPE NUGGETS | 1000 gr.

FIO6104

BOCC. MELANZANE | 1000 gr.

FIO4604

INSALATA RUSSA CRISPY | 1000 gr.

FIO2804

POLENTINE STICK | 1000 gr.

FIO4904

ARANCINI MIGNON | 1000 gr.

FIO5609

PANZEROTTI MIGNON | 1000 gr.

FIO99604

MISTO DELL'ORTO PAST. | 1000 gr.

FIO99574

ANELLI DI CIPOLLA | 1000 gr.

FIO9207

FRITTELLA DI MARE | 1000 gr.

FIO9307

FRITTELLA GRANCHIO | 1000 gr.

FIO9407

FRITTELLA PATATE ROSM. | 1000 gr.

FIO9507

FRITTELLA PEPERONI | 1000 gr.

FIO9607

FRITTELLA PIZZAIOLA | 1000 gr.



300351
SALATINI ASSORTITI 8 GUSTI
1 kg. X 4 buste | 200° | 10 min.



300350
PIZZETTE MIGNON
1 kg. X 4 buste | 200° | 10 min.



300353
TORTA PASQUALINA RIC/SPINACI
700 gr. X 6 | 200° | 10 min.



091
PATATE PREFRITTE
2,5 kg. X 5 | 200° | 10 min.



200146
MEXICO WINGS
2500 gr. | 60/65 pz.



200157
SPEEDY POLLO NEW
2000 gr. | 133 pz.



200141
SPEEDY BANDIDOS
2000 gr. | 100 pz.



200132
METEORITOS
2000 gr. | 58 pz.



200111
CROCK'N SEEDS
2000 gr. | 111 pz.



200107A
SPEEDY POPS
1000 gr. | 125 pz.



200149
BOCCONCINI DI POLLO
2000 gr. | 115 pz.

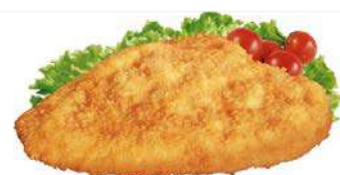

639014
COTOLETTA DI POLLO
96 gr. | 26 pz.



200156
GRAN MILANESE
150 gr. | 14 pz.



200126
GIGA CUTLET
250 gr. | 12 pz.



200154
GRAN BROCHETTE (SPIEDONE)
100 gr. | 15 pz.



200069
HAMBURGER GRIGLIATO
78 gr. | 26 pz.



200155
GRILLED STRIPS
2500 gr.

PANINOTECA

ATP, PIADINE E SNACK

ATP è una tecnologia di confezionamento e conservazione dei prodotti alimentari che consente di aumentare il periodo di "vita" e di mantenere inalterate le caratteristiche del prodotto. È una tecnologia di conservazione che si applica in particolare agli alimenti freschi e deperibili che possono così prolungare la shelf life senza incidere su sapore o proprietà nutrizionali ma garantendo invece la sicurezza alimentare dei prodotti stessi.





MM669
CAMPAGNOLO
400 gr. | 6 pz.



MM660
BRUSCHETTA MAGO
400 gr. | 8 pz.



MM1136
**HAMBURGERINI
AL SESAMO**
200 gr. | 12 pz.



MM441
**MORBIDELLE
TRAMEZZINO**
250 gr. | 16 pz.



MM101
**CASERECCI
ALL'ACQUA**
200 gr.

MM031
**CASERECCI
AI 7 CEREALI**
200 gr.



MM121
**CASERECCI OLIVE
NERE E TAGGIA.**
200 gr.



MM933
**GRISSINI
AL RISO VENERE**
200 gr.

MM0360
**GRISSINO
BREZEL CON SALE**
175 gr.



MM1093
**BRUSCHETTA
GRIGLIATA OLIO**
80 gr. | 18 pz.



MM1148
**STUZZICHELLI
NUVOLA CLASSICO**
200 gr. | 12 pz.



MM1142
**STUZZICHELLI
NUV. MEDITERRANEI**
350 gr. | 12 pz.



MM1073
**SECCHIELLO
TARALLI**
1000 gr.



MM1106
**FOCACCINE
SNACK CON OLIO**
150 gr.



MM0359
**FOCACCINE
BREZELINA**
150 gr.





PF268
**MAXI
HOT DOG**

75 gr. | 32 pz.



PF262
**MAXI
HAMBURGER SESAMO**

75 gr. | 28 pz.



PF510
**PAN SANDWICH
BIANCO**

450 gr. | 10 pz.



PF029
TIGELLA

220 gr. | 12 pz.



PF180
**REAL PIADA
ATP**

110 gr. | 3x12 pz.



PF181
**REAL PIADA
ALL'OLIO EVO**

110 gr. | 3x12 pz.



PF054
PIADA SFOGLIATA

110 gr. | 30 pz.



GI01580
BASTONCINI SFUSI NATURALI

500 gr.



GI01581
BASTONCINI SFUSI FORMAGGIO

500 gr.



GI01583
BASTONCINI SFUSI SPECK

500 gr.



GI02698
MINI-STIRATI SESAMO

900 gr.



GI02699
MINI-STIRATI VARI

900 gr.



GI02696
PERLE DI BREZEL

1,6 kg.



GI02690
COCKTAIL MIX

1,5 kg.



GI01591
GILLINI GOURMET NATURALI

1 kg.



GI01595
GILLINI OLIVE-POM-ORIGANO

1 kg.



LAPRING100
PRINGLES PAPRIKA (GIALLO)

12x40 gr.



LAPRING105
PRINGLES ORIGINAL (ROSSO)

12x40 gr.



LAPRING125
PRINGLES CR.&ONION (VERDE)

12x40 gr.



SAIW100
FONZIES

50 pz.



PATA131
TORTILLA PATA CLASSICA

8x400 gr.



950256
ARACHIDI SALATE ARGENTINE

1 kg.



FD006
CROCCANTELE PROS. CRUDO

25x35 gr.



FD001
CROCCANTELE BACON

25x35 gr.



FD002
CROCCANTELE KETCHUP

25x35 gr.



FD005
CROCCANTELE PIZZA

25x35 gr.



FD007
CROCCANTELE POLLO ARROSTO

25x35 gr.



FD008
CROCCANTELE BBQ RIBS

25x35 gr.



FD009
TARALLINO CLASSICO

25x35 gr.



7501974
PATATINA GRIGLIATA
20x180 gr.



7501973
PATATINA CLASSICA
20x180 gr.

7501975
7507150
PATATINA GUSTO RICCO /BARBECUE
20x170 gr.



7501964
CLASSICHE - PATATINE
50g.



7501965
PATATINE RUSTICHE
40g.



7501968
PATATINE GUSTO BARBECUE
40g.



7501966
PATATINE PAPRIKA
40g.



7501969
PATATINE GUSTO KETCHUP
40g.



7501682
PATATINE STICK
45g.



7502082
CORNETTI DI MAIS AL FORMAGGIO
45g.



7502083
PALLINE DI MAIS AL FORMAGGIO
45g.



7502084
ANELLI PIZZA
45g.



7504018
POP CORN
40g.



PATATINE SORPRESA
30g.



PANINOTECA

Pane e Piadine PANE E PIADINE GELO

Consegniamo pane ogni giorno. I nostri prodotti, consegnati parzialmente cotti e surgelati, semplificano le operazioni in negozio, consentendoti di guadagnare tempo e avere pane fresco a qualsiasi ora del giorno.

Abbiamo anche una grande varietà di forme e molti dei nostri prodotti sono disponibili anche nella versione pretagliata, per consentire a chi li farcisce di semplificare al massimo le operazioni in cucina.





300155
CIABATTINA INTERA
120 gr. | 25 pz.



300156
CIABATTINA PRETAGLIATA
120 gr. | 26 pz.



300158
CIABATTINA AI CEREALI PRET.
120 gr. | 26 pz.



300116
BARRETTA AI CEREALI
140 gr. | 45 pz.



300265
PANE BUGHY PRETAGLIATO
80 gr. | 54 pz.



600477
PANINO GRIGLIATO
110 gr. | 36 pz.



300262
CIABATTA RUSTICA ALL'OLIO
280 gr. | 14 pz.



300190
PANINO CRISTALLO PRETAGLIATO
95 gr. | 48 pz.



8173
FOCACCIOTTO
80 gr. | 32 pz.



8172
TRECCIA CON SEMI
100 gr. | 30 pz.



600460
SCHIACCIATA PRET.
100 gr. | 32 pz.



8991
MINI PANINO AL LATTE
25 gr. | 75 pz.



300219
PANPIZZA
120 gr. | 30 pz.



300225
CONCHIGLIA
110 gr. | 60 pz.



300130
SCHIACCIATINA PRETAGLIATA
130 gr. | 16 pz.



300292
PIADA EXTRA FINE Ø 24/26
110 gr. | 60 pz.



300294
PIADA MAXI ROMAGNOLA Ø 26/28
120 gr. | 60 pz.



300238
SPIANATA Ø 29
220 gr. | 20 pz.



600314
PANINO HOT DOG
75 gr. | 36 pz.



81580
MAXI BURGER SESAMO
130 gr. | 16 pz.



300113
BAGUETTE NAZIONALE
280 gr. | 40 pz.



300267
BAGUETTINO FRANCESE
150 gr. | 40 pz.



300193
BAGUETTE PAYSANNE
280 gr. | 35 pz.



300120
BAGUETTE PRECOTTA FRANCESE
280 gr. | 33 pz.



300300
MINI FRUSTINO
35 gr. | 115 pz.



300127
BAGUETTE 6 CEREALI
250 gr. | 40 pz.



300133
KAISER VIENNESE
65 gr. | 100 pz.



300192
MINI PANE CRISTALLO
180 gr. | 30 pz.



300191
PANE CRISTALLO
270 gr. | 18 pz.



300355
TOAST GRANDE
550 gr. | 2 pz.



300215
TOAST GIGANTE
800 gr. | 2 pz.



300240
TOAST AMERICANO
600 gr. | 2 pz.



300221
PANCARRÉ TRAMEZZINI
1 kg.



300268
PANE BRUSCHETTA OVALE
500 gr. | 6 pz.



300320
GRAN BRUSCHETTA MARGHERITA
230 gr. | 16 pz.

PANINOTECA

Focaccine e Pizza

A colazione, a merenda, come aperitivo, a pasto o fuori pasto, la focaccia in Liguria è presente sempre e ovunque: ogni paese ha la sua ricetta, la sua specialità.

Ancora oggi la focaccia genovese, sottile e soffice, ha grande successo, nota e apprezzata per la sua semplicità oltre che per la sua fragranza.





55657
FOCACETTA ALL'OLIO PRET.

120 gr. | 16 pz.



FRA3901P
FOCACINA RUSTICA PRET. Ø 14

100 gr. | 24 pz.



FRA3906
FOCACINA RUSTICA PICC. Ø 8/9

23 gr. | 87 pz.



8938
FOCACIA SPECK E BRIE

300 gr. | 6 pz.

8936
FOCACIA RUCOLA E STRACCHINO

300 gr. | 6 pz.



8937
FOCACIA COTTO E MOZZARELLA

330 gr. | 6 pz.



600315
FOCACIA TOSCANA

220 gr. | 20 pz.



300237
FOCACIA ALL'OLIO

180 gr. | 30 pz.



FRA01425
FOCACIA GRANO DURO QUADR.

850 gr. | 5 pz.



FRA0101
FOCACIA TRADIZIONALE

550 gr. | 6 pz.



FRA0120
FOCACIA VEGANA

600 gr. | 6 pz.



FRA270105
FOCACIA VENERE

580 gr. | 5 pz.



FRA020105
FOCACIA CIPOLLA

750 gr. | 5 pz.



FRA320205
FOCACIA POMODORINI

850 gr. | 5 pz.



FRA110205
FOCACIA OLIVE TOPPING

700 gr. | 5 pz.



FRA1206
FOCACIA CON STRACCHINO

780 gr. | 6 pz.



FRA190205
FOCACIA SICILIANA

850 gr. | 5 pz.



300118
FOCACIA VEGETARIANA

800 gr. | 4 pz.



300222

PIZZELLA/GRANP. MARGHERITA

200 gr. / 350 gr. | 12 pz.



300224

PIZZELLA/GRANP. PROSCIUTTO

220 gr. / 400 gr. | 12 pz.



300223

PIZZELLA/GRANP. SALAME PICC.

225 gr. / 370 gr. | 12 pz.



300226

PIZZELLA/GRANPIZZELLA PROSCIUTTO E FUNGHI

225 gr. / 420 gr. | 12 pz.



300227

PIZZELLA/GRANPIZZELLA VERDURE AL VAPORE

230 gr. / 415 gr. | 12 pz.



300229

PIZZELLA WURSTEL

225 gr. | 12 pz.



300228

PIZZELLA/GRANPIZZELLA 4 FORMAGGI

235 gr. / 360 gr. | 12 pz.



8180

PINSA ALLA ROMANA

210 gr. | 16 pz.



8933

PINSA ALLA ROMANA RUSTICA

210 gr. | 16 pz.



MAC1000972

PIZZA SCROCK 55X25

8 pz.



300305
PIZZA MARGHERITA

580 gr. | 8 pz.



300261
PIZZA MARGHERITA 30X40

1000 gr. | 4 pz.



300254
BASE PER PIZZA 30X40

750 gr. | 8 pz.



300358
PIZZETTE MARGHERITA

30 gr. | 66 pz.



300302
DEMI PIZZE

150 gr. | 36 pz.



Q0408
PIZZA TONDA AL TEGAMINO

160 gr. | 18 pz



780181
2 PIZZE MARGHERITA

660 gr. | 6 pz.



780180
4 PIZZETTE MARGHERITA

560 gr. | 8 pz.



780197 • 780198
PIZZA 2^ SCELTA

Margherita • Super margherita | 2x5 pz.

CRP01SUPERLMX1
PIZZA SUPERMARGHERITA

390 gr. | 5 pz.



CRP02LMX1
PIZZA CAPRICCIOSA

410 gr.



Assortimento Edna

ASSORTIMENTO EDNA

EDNA International – il vostro competente partner per prodotti da forno surgelati. Abbiamo anche una grande varietà di forme e molti dei nostri prodotti sono disponibili anche nella versione pretagliata, per consentire a chi li farcisce di semplificare al massimo le operazioni in cucina.

Disponibile il catalogo EDNA completo per tutto l'assortimento su ordinazione.





E00000145
BREZEL GIGANTE

150 gr. | 16 pz.



E00001899
BREZEL PRONTO CON SALE

100 gr. | 60 pz.



E00000458
FILONCINO LAUGEN

125 gr. | 30 pz.



E00000871
SINFONIA DI PANE

1170 gr. | 6 pz.



E00000793
PANINO CUORE CON CEREALI

60 gr. | 50 pz.

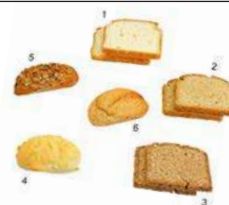

E00002125
MIX PANE S/GLUTINE 6 VAR.

56 gr. | 60 pz.



E00000978
BAGEL AL SESAMO

75 gr. | 36 pz.



E00002503
BURGER CON SESAMO

75 gr. | 40 pz.



E00002356
FLYNG BURGER MIX 4 VAR.

18 gr. | 160 pz.



E00001951
RED LOVE BURGER

100 gr. | 20 pz.



E00001845
BLACK BURGER

100 gr. | 20 pz.



E00001826
YELLOW BURGER

100 gr. | 20 pz.



E00000252
RUSTY BURGER

100 gr. | 40 pz.



E00002265
HAPPY BURGER

100 gr. | 20 pz.



E00001367
CRÊPES AL NATURALE

62,5 gr. | 80 pz.



E00003300
ASSORTIMENTO DI ALMONDY

3 torte senza glutine | 960 gr. | Ø 27 cm



E00001304
WAFFEL

90 gr. | 40 pz.



E00001301
PANCAKE

40 gr. | 120 pz.

PIATTI PRONTI



GASTRONOMIA FRESCA

Lo dice la parola stessa "Siamo pronti"! Il brand mette in evidenza due delle caratteristiche dei prodotti: la velocità di preparazione e l'amore che c'è dietro ad ogni ricetta. Siamo Pronti è il brand di Tempestini S.P.A. dedicato al mercato dell'Ho.Re.Ca. che identifica la linea dei primi e secondi piatti monoporzione.





Monoporzioni



85201
LASAGNE ALLA BOLOGNESE

300 g. | frigorifero 0°C / +4°C.



85217
LUNETTE VERDI ALLO ZOLA

300 g. | frigorifero 0°C / +4°C.



85231
CASONCELLI AL BURRO E PANC.

300 g. | frigorifero 0°C / +4°C.



85214
RAVIOLI BURRO E SALVIA

300 g. | frigorifero 0°C / +4°C.



85210
QUADRETTI NOCI E TARTUFO

300 g. | frigorifero 0°C / +4°C.



85219
FAGOTTINI AL SALMONE

300 g. | frigorifero 0°C / +4°C.



85274
MELANZANE ALLA PARMIGIANA

300 g. | frigorifero 0°C / +4°C.



85237
**TORTELLI MUGELLANI
DI PATATE AL RAGÙ**

300 g. | frigorifero 0°C / +4°C.



85238
**TORTELLI MUGELLANI
ALLA CARRETTIERA**

300 g. | frigorifero 0°C / +4°C.



85203
TORTELLINI ALLA PANNA

250 g. | frigorifero 0°C / +4°C.



85228
TORTELLINI AL RAGÙ

300 g. | frigorifero 0°C / +4°C.



85226
PENNE AMATRICIANA

300 g. | frigorifero 0°C / +4°C.



85204
PENNE ARRABBIATA

300 g. | frigorifero 0°C / +4°C.



85207
PENNE ALLA BOSCAIOLA

300 g. | frigorifero 0°C / +4°C.



85938
GNOCCHI AL RAGÙ

300 g. | frigorifero 0°C / +4°C.



85239
GNOCCHI AL FORMAGGIO

300 g. | frigorifero 0°C / +4°C.



85206
GNOCCHI AL PESTO

300 g. | frigorifero 0°C / +4°C.



85230
PAELLA ALLA VALENCIANA

300 g. | frigorifero 0°C / +4°C.



85255
RISOTTO ALLA MARINARA

300 g. | frigorifero 0°C / +4°C.



85202
RISOTTO AI FUNGHI PORCINI

300 g. | frigorifero 0°C / +4°C.



85216
RISOTTO ZAFFERANO E SPECK

300 g. | frigorifero 0°C / +4°C.



85233
RISOTTO RADICCHIO ROSSO

300 g. | frigorifero 0°C / +4°C.



GIMI211E
PIZZOCCHERI VALTELLINESI

300 g. | frigorifero 0°C / +4°C.



Monoporzioni



85205
TAGLIATELLE AI FUNGHI

300 g. | frigorifero 0°C / +4°C.



85213
TAGLIATELLE AL RAGÙ

300 g. | frigorifero 0°C / +4°C.



85959
PAPPADELLE AL CINGHIALE

300 g. | frigorifero 0°C / +4°C.



85221
BIGOLI AL POMODORO

300 g. | frigorifero 0°C / +4°C.



85218
GRAMIGNA CON SALSICCIA

300 g. | frigorifero 0°C / +4°C.



85234
**MINISTRA DI PANE
RIBOLLITA**

300 g. | frigorifero 0°C / +4°C.



85223
PASTA E FAGIOLI

300 g. | frigorifero 0°C / +4°C.



85222
PASTA E CECI

300 g. | frigorifero 0°C / +4°C.



85280
ZUPPA DI FARRO

300 g. | frigorifero 0°C / +4°C.



85225
ZUPPA D'ORZO

300 g. | frigorifero 0°C / +4°C.



85297
PASTA E CECI IN COCCIO

250 g. | frigorifero 0°C / +4°C.



85296
ZUPPA DI FARRO IN COCCIO

250 g. | frigorifero 0°C / +4°C.



85251
INS. RISO FREDDO

250 g. | frigorifero 0°C / +4°C.



85232
INS. FARRO FREDDO

250 g. | frigorifero 0°C / +4°C.



85252
PASTA FREDDA

250 g. | frigorifero 0°C / +4°C.



85236
COUS COUS VEG.

250 g. | frigorifero 0°C / +4°C.



85269
INSALATA DI POLLO

250 g. | frigorifero 0°C / +4°C.



85285
FAGIOLINI E MAZZANCOLLE

300 g. | frigorifero 0°C / +4°C.



85281
SEPIE IN ZIMINO

250 g. | frigorifero 0°C / +4°C.



85271
SPEZZATINO CON PISELLI

250 g. | frigorifero 0°C / +4°C.



85272
TACCHINO CON CAROTE

250 g. | frigorifero 0°C / +4°C.



85229
TRIPPA ALLA FIORENTINA

250 g. | frigorifero 0°C / +4°C.



85287
POLLO AL CURRY

250 g. | frigorifero 0°C / +4°C.



85279
CINGHIALE IN UMIDO

250 g. | frigorifero 0°C / +4°C.



PIATTI PRONTI



SURGELATI BONCHEF

BonChef è una linea pensata per pause sfiziose e pranzi all'insegna del gusto: dai prodotti rompi-digiuno alle pause per il pranzo fuori casa, sino al tanto atteso momento dell'aperitivo serale. Primi e secondi piatti pronti, sane e nutrienti verdure, tante tipologie di pane e pizze della tradizione e dell'innovazione, snack salati e torte.

L'ampia offerta dei prodotti di BonChef è caratterizzata dall'alto contenuto di servizio, con tutta la garanzia della qualità Sammontana che offre supporto anche per la cottura perfetta e la preparazione impeccabile.





600430

LASAGNE RICCHE ALL'EMILIANA

350 gr. | 8 pz. | 6 minuti a 900W



600436

CANNELLONI RICOTTA E SPINACI

300 gr. | 4 pz. | 6 minuti a 900W



600443

PENNETTE ALL'ARRABBIATA

300 gr. | 8 pz. | 6 minuti a 900W



600426

MEZZE PENNE AL SALMONE

300 gr. | 4 pz. | 6 minuti a 900W



600446

PENNETTE ALL'AMATRICIANA

300 gr. | 4 pz. | 6 minuti a 900W



600423

MACCHERONI ALLA SALSICCIA

300 gr. | 4 pz. | 6 minuti a 900W



8184

MEZZE PENNE AL POMODORO

300 gr. | 4 pz. | 6 minuti a 900W



600415

ORECCHIETTE ALLE CIME DI RAPA

300 gr. | 4 pz. | 6 minuti a 900W



600422

TROFIE AL PESTO

300 gr. | 4 pz. | 6 minuti a 900W



600427

FUSILLI DI MAIS AL RAGÙ

300 gr. | 4 pz. | 6 minuti a 900W



600451

SPAGHETTI POM. BASILICO

300 gr. | 4 pz. | 6 minuti a 900W



600424

SPAGHETTI CACIO E PEPE

300 gr. | 4 pz. | 6 minuti a 900W



600440

SPAGHETTI ALLA CARBONARA

300 gr. | 8 pz. | 6 minuti a 900W



600421

TAGLIATELLE AI FUNGHI

300 gr. | 4 pz. | 6 minuti a 900W



600435

TAGLIATELLE ALLA BOLOGNESE

300 gr. | 4 pz. | 6 minuti a 900W



600437

GNOCCHI AI FORMAGGI

300 gr. | 4 pz. | 6 minuti a 900W



600418

GNOCCHI VERDI AL PESTO ROSSO

300 gr. | 4 pz. | 6 minuti a 900W



600438

LUNETTE SPECK E BRIE

300 gr. | 4 pz. | 6 minuti a 900W



600433

TORTELLINI PANNA E PROSCIUTTO

300 gr. | 8 pz. | 6 minuti a 900W



600880

POLPETTE VEG. ZUCCA/CAROTE

1200 gr.



600420

RISOTTO DI MARE

300 gr. | 4 pz. | 6 minuti a 900W



600454

RISOTTO AI FUNGHI

300 gr. | 4 pz. | 6 minuti a 900W



600881

POLPETTE VEG. CON RAPE ROSSE

1200 gr.



600445

RISOTTO ALLO ZAFFERANO

300 gr. | 4 pz. | 6 minuti a 900W



8908

RISOTTO AGLI ASPARAGI

300 gr. | 4 pz. | 6 minuti a 900W



600882

POLPETTE VEG. CON SPINACI

1200 gr.



8909

INS. DI RISO NERO AL SALMONE

300 gr. | 4 pz. | 6 minuti a 900W



8910

VELLUTATA ALLA ZUCCA

300 gr. | 6 pz. | 6 minuti a 900W



8911

VELLUTATA ZUCCHINE E PISELLI

300 gr. | 6 pz. | 6 minuti a 900W



600453

COTOLETTA DI POLLO CON PATATE

300 gr. | 4 pz. | 6 minuti a 900W



600452

ARROSTO DI MAIALE CON PATATE

300 gr. | 4 pz. | 6 minuti a 900W



600448

MELANZANE ALLA PARMIGIANA

300 gr. | 4 pz. | 6 minuti a 900W



1102

LASAGNE ALLA BOLOGNESE

2400 gr. | 2 pz.



1100

CANNELLONI RICOTTA E SPINACI

2400 gr. | 2 pz.



1103

MELANZANE ALLA PARMIGIANA

2400 gr. | 2 pz.



GE53077
RAVIOLI RIC.SPINACI

350 gr. | 8 pz. | 6 minuti a 900W



GE53078
FETTUCINE AL RAGÙ

350 gr. | 8 pz. | 6 minuti a 900W



GE53079
BUCATINI AMATRICIANA

350 gr. | 8 pz. | 6 minuti a 900W



GE53080
GNOCCHI SORRENTINA

350 gr. | 10 pz. | 6 minuti a 900W



GE53081
PENNE ALL'ARRABBIATA

350 gr. | 10 pz. | 6 minuti a 900W



GE53082
PENNE SALMONE/GAMB.

350 gr. | 10 pz. | 6 minuti a 900W



GE53086
SPAGHETTI CARBONARA

350 gr. | 8 pz. | 6 minuti a 900W



GE53087
SPAGHETTI POMODORO

350 gr. | 8 pz. | 6 minuti a 900W



GE53088
TAGLIATELLE AI PORCINI

350 gr. | 8 pz. | 6 minuti a 900W



GE53090
RISOTTO AI FUNGHI

350 gr. | 10 pz. | 6 minuti a 900W



SUX112
FIL. MERLUZZO PATATE

300 gr. | 4 pz. | 6 minuti a 900W



SUX102
POLLO FUNGHI PATATE

300 gr. | 4 pz. | 6 minuti a 900W



SUZ338
SVITATI AI FORMAGGI

300 gr. | 4 pz. | 6 minuti a 900W



SUZ369
TORTELLINI RAGÙ BOLOGNESE

300 gr. | 4 pz. | 6 minuti a 900W



SUZ337
RISOTTO ALLA PARMIGIANA

300 gr. | 4 pz. | 6 minuti a 900W



300701
RISOTTO AI FUNGHI PORCINI

300 gr. | 4 pz. | 6 minuti a 900W



616002
RISOTTO CON PROV. E RADICCHIO

300 gr. | 6 pz. | 6 minuti a 900W



616006
RISOTTO ALLO ZAFFERANO

300 gr. | 6 pz. | 6 minuti a 900W



616007
RISOTTO AGLI ASPARAGI

300 gr. | 6 pz. | 6 minuti a 900W



300711
RISOTTO ALLE VERDURE

300 gr. | 4 pz. | 6 minuti a 900W



300704
RISOTTO ALLA PARMIGIANA

300 gr. | 4 pz. | 6 minuti a 900W



MATERIALE *per i punti vendita*



8179
PANE BUN SESAMO
75 gr. | Ø 110 mm. | 30 pz.



8944
PANE BUN BRIOSCIATO
90 gr. | Ø 110 mm. | 36 pz.



4106
HAMBURGER CON CARNE BOVINA
100 gr. | Ø 100 mm. | 24 pz.



8057
HAMBURGER CON BLACK ANGUS
150 gr. | Ø 115 mm. | 12 pz.



8181
BURGER VEG. CON MELANZANE
100 gr. | Ø 100 mm. | 12 pz.



600475
COTOLETTA SUPER
96 gr. | 20 pz.



8964
SALSICCIA DI SUINO GRIGLIATA
100 gr. | 40 pz.



PANINOTECA

Freschi
FRESCHI

Una vasta gamma di ottime ricette, dai gusti tradizionali o ricercati per invogliare anche il più esigente dei Vostri clienti. Grazie alle ottime materie prime fornite dalle migliori aziende alimentari ed alle lavorazioni accurate in fase di produzione. Rapidi e semplici da preparare: pochi istanti in piastra oppure semplicemente scartando la confezione, potrete offrire un prodotto come appena fatto.



CIABATTE



Alpino

Pane ciabattina, speck, Funghi, Formaggio Edamer.



Ciabatta al Crudo

Pane ciabattina di semola, prosciutto crudo, mozzarella.



Peter

Pane ciabattina, prosciutto cotto, mozzarella.

Valdostano

Pane ciabattina di semola, speck, Formaggio tipo Brie.



Belzebù

Pane puccia, salame piccante, Formaggio Edamer.



Zoccoletto al Cotto Fumè

Pane puccia, prosciutto di Praga, Formaggio Emmenthal.



Specialità

Prelibato

Pane pannocchia, pancetta arrotolata, mozzarella.



Tonnaro

Pane al mais, salsa tonno, mozzarella.

CARNI



Milano

Pane tartaruga, cotoletta di pollo cotta, Formaggio Edamer.



Panciccio

Pane Piumino, salsiccia di suino grigliata.

Piadineria



Romagna Crudo

Piada, prosciutto crudo, mozzarella.



RIGAMONTI
Qualità dal 1918

Bresaolone

Pane "ciriola", bresaola Punta d'Anca "Rigamonti", Formaggio Edamer.



Pizzeria

Bonburger

Hamburger sesamo, Formaggio Edamer, hamburger di manzo cotto grigliato.



Trancio Margherita

Pasta da pizza, pomodoro, Formaggio Edamer.



Focacceria

Delizia

Focaccia genovese all'olio, prosciutto cotto, Formaggio Edamer.



Schiacciata al Crudo

Schiacciata, prosciutto crudo e Formaggio Edamer.

Hot-Dog

Pane hot-dog sesamo, wurstel.



LINEA

VEGETARIANA

Multicereali alle Verdure

Ciabatta multicereali, verdure grigliate.



Toastone alle Verdure e Formaggio

Pane in cassetta ai cereali, verdure grigliate, Provola affumicata.



Romagna Cotta

Piada, prosciutto cotto, mozzarella.



TOAST & TOASTONI

Fungone

Pane americano, prosciutto cotto, Formaggio Edamer.



Toast Classico

Pane toast, prosciutto cotto, Formaggio Edamer.



Toastone Rustico ai Cereali

Pane in cassetta ai cereali, speck e Provola affumicata.





PASTICCERIA

PASTICCERIA VENETA

EST 1978

VENEZIA

TORTE

La storia della pasticceria veneta è un lungo racconto che inizia ai tempi di Marco Polo, nell'epoca in cui Venezia già si distingueva per la sua indole cosmopolita, la sua apertura nei confronti di Paesi e culture lontane, la sua voglia di assaporare e mescolare i profumi, sapori e costumi del mondo. La sua anima è all'origine della sua magia, la sua golosa curiosità alla base delle sue deliziose bontà gastronomiche e dolciarie.





400203
CROSTATA AI FRUTTI DI BOSCO

intera • pretagliata 14 ft.



400209
CROSTATA DI FRUTTA

intera • pretagliata 14 ft.



400114
CROSTATA AL CACAO

intera • pretagliata 16 ft.



400109
CROSTATA AL LIMONE

intera • pretagliata 16 ft.



400117
CROSTATA ALLE PERE

intera • pretagliata 16 ft.



400118
CROSTATA ALLE MELE

intera • pretagliata 16 ft.



400116
CROSTATA DI NOCI

intera • pretagliata 16 ft.



400113
TORTA DELLA NONNA

intera • pretagliata 16 ft.



400097
MOUSSE AI FRUTTI DI BOSCO

intera



400096
MOUSSE AL LIMONE

intera



400126
SACHER

intera



400124
TORTA SELVA NERA

intera



400125
SAINT HONORÈ

intera



400147
FOCACCIA MORBIDA AI FICHI
pretagliata 12 ft.



400142
FOC. MORBIDA PERE E CIOCCOLATO
pretagliata 12 ft.



400143
FOCACC. MORBIDA ALL'ALBICOCCA
pretagliata 12 ft.



400144
FOCACCIA MORBIDA ALL'ANANAS
pretagliata 12 ft.



400145
FOCACCIA MORBIDA ALLE MELE
pretagliata 12 ft.



400146
FOCACCIA MORBIDA AL COCCO
pretagliata 12 ft.



400123
CROSTATA APRY
pretagliata 16 ft.



400122
CROSTATA CREMA GIANDUIA
pretagliata 12 ft.



400152
CROSTATA ALLE CAROTE
pretagliata 14 ft.



400150
CROSTATA CONF. FRUTTI DI BOSCO
pretagliata 12 ft.



400345
TORTA TIRAMISÙ
pretagliata 12 ft.



400346
CRAMBLE DI PERE
pretagliata 12 ft.



400208
PROFITTEROL BIANCO

24 pz.



400207
PROFITTEROL CACAO

24 pz.



400201
DELIZIA

trancio



400008
MILLEFOGLIE

trancio



400007
MERINGATA

trancio



400006
MERINGATA AL CARMELLO SALATO

trancio



400307
MOKA

trancio



400010
BACIO

trancio



400009
SAINT HONORÉ

trancio



400012
TIRAMISÙ AI SAVOIARDI

trancio



MONOPORZIONI



B1644
MARITAZZO CON PANNA
90 gr. | 12 pz.



B0144
SOUFFLÉ AL PISTACCHIO
90 gr. | 12 pz.



B1467
SOUFFLÉ AL CIOCCOLATO
90 gr. | 12 pz.



B0474
PIRAMIDE AL CIOCCOLATO
65 gr. | 6 pz.



B0217
MONO CHEESECAKE FRAGOLA
90 gr. | 9 pz.



B0267
CROCCANTE ALLE MANDORLE
95 gr. | 9 pz.



B0451
TORTINA DELLA NONNA
85 gr. | 12 pz.



B0514
SEMIFREDDO AL TORRONCINO
75 gr. | 12 pz.



B0513
SEMIFREDDO AL CAFFÈ
70 gr. | 12 pz.



B0517
TARTUFO BIANCO
75 gr. | 12 pz.



B0533
TARTUFO NERO
85 gr. | 12 pz.



B0623
CROCCANTE ALL'AMARENA
95 gr. | 9 pz.



B1251
TARTUFO LIMONCELLO
85 gr. | 12 pz.



B0179
TARTUFO ALLA NOCCIOLA
75 gr. | 12 pz.



B0655
SCRIGNO MELE E MANDORLE
60 gr. | 6 pz.



B0657
MELANGE FRAGOLINE E RIBES

100 gr. | 6 pz.



B0682
RICOTTA E PERE

95 gr. | 6 pz.



B0821
COPPA CREMA PISTACCHIO

100 gr. | 6 pz.



B0142
SOUFFLÉ GLACE

90 gr. | 9 pz.



B0844
RONDÒ VANIGLIA FRAGOLA

80 gr. | 6 pz.



B0575
CANNOLO SICILIANO

120 gr. | 12 pz.



B1281
TIRAMISÙ SAVOIARDI

110 gr. | 10 pz.



B1346
GOCCIA TIRAMISÙ

48 gr. | 6 pz.



B1373
COPPA FRAGOLE E MASCARPONE

110 gr. | 12 pz.

B0689
CIP CIOK

40 gr. | 12 pz.



B2542
MAN IN BLACK

40 gr. | 12 pz.



B0686
HIP HOP

40 gr. | 12 pz.



B0687
PAN DAN

40 gr. | 12 pz.



B1326
PIRATA

40 gr. | 12 pz.



B1327
PRINCIPESSA

40 gr. | 12 pz.



B0985
RABBIT

40 gr. | 12 pz.



B0528
TWITTY

40 gr. | 12 pz.





GELATO

il gelato del goloso
ARTIGIANALE

Gelato Artigianale GELATO ARTIGIANALE

Il laboratorio artigianale "Il gelato del Goloso" nasce nel 1992, negli anni non ha fatto altro che crescere e perfezionarsi ed oggi, continua a regalare ai palati della sua affezionata clientela un mix di gusto, freschezza, cremosità e soddisfazione.

Vi è una cura meticolosa nella sperimentazione dei nuovi gusti e nella messa a punto di un sofisticato monitoraggio della qualità del prodotto finito.

La gamma dei prodotti è ampia e in grado di soddisfare le esigenze dei golosi più accaniti. Le materie prime utilizzate sono di primissima qualità, esse vengono infatti selezionate accuratamente ed il risultato è strepitoso... Provare per credere!



DALLA MATERIA PRIMA AL PRODOTTO DI QUALITÀ

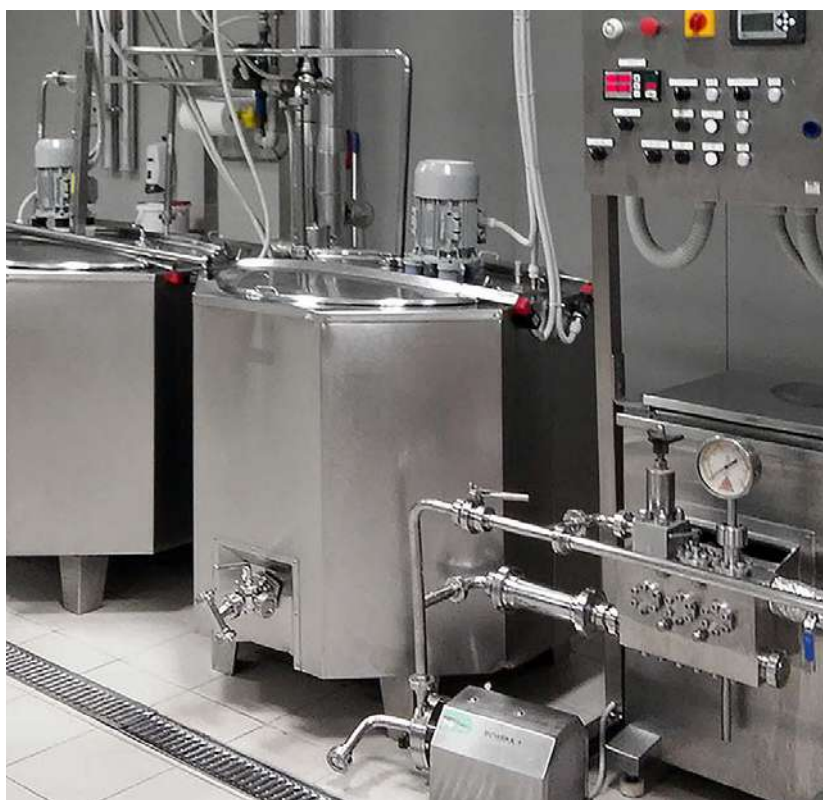

Il nostro gelato artigianale è prodotto con ingredienti freschi di altissima qualità. La miscela base per tutti i nostri gusti è sottoposta ad un processo di pastorizzazione che rende igienicamente sicuro il prodotto e ad uno di omogeneizzazione che ne aumenta la cremosità. Al fine di ottenere un ottimo gelato, quest'ultimo viene sottoposto ad un lento processo di maturazione ad una temperatura di 4°C, in questa fase la miscela acquisisce maggiore densità e viene scongiurato il pericolo di formazione di grossi cristalli di ghiaccio. L'ultima fase a cui viene sottoposto il prodotto è la mantecazione, cioè il passaggio dallo stato liquido a quello solido. Questa è una delle operazioni più importanti, da essa dipendono infatti la qualità e la resa del prodotto. Ciò che contraddistingue il nostro gelato è la continua ricerca di ottime materie prime e la passione che mettiamo nella creazione di ogni singola vaschetta, il latte e la panna sono rigorosamente freschi e di ottima qualità e la frutta che utilizziamo è sottoposta ad un'attenta selezione. Il nostro obiettivo è quello di stupirvi con il nostro gelato, di emozionarvi, di farvi tornare bambini con una delle cose più semplici e buone del mondo.



FORMATI E ATTREZZATURE

Nel nostro laboratorio creiamo gelati in vari formati, dalle coppette monodose da 85g per una pausa golosa fino alle vaschette professionali da 2,5 lt e da 5 lt e carapine da 6 lt, utilizzate nelle gelaterie, passando per le vaschette create ad hoc per le famiglie da 500g.

Proponiamo attrezzature frigorifere in comodato d'uso gratuito per gli esercenti che utilizzano le nostre referenze. Abbiamo a disposizione vetrine refrigerate e frigo a pozzetto in varie misure per adattarsi alle esigenze dei vari punti vendita. Completiamo il tutto con un qualificato servizio di consegne che garantisce puntualità, precisione ed efficienza, indice di grande professionalità.





PANNA



CAFFÈ



STRACCIATELLA



CIOCCOLATO



KINDERÉ



NOCCIOLA



YOGURT



CREMA



BISCOTTO



NUTELLA



LIQUIRIZIA



VAR AMARENA



FRUTTI DI BOSCO



LIMONE



PESCA



FRAGOLA



MANGO



PISTACCHIO



PUFFO

Espresso



SOFFICE E CREMOSO

È soffice e cremoso, ed è adatto per chi ha limiti di spazio. Il gelato artigianale italiano si è contraddistinto nel corso del tempo per le continue innovazioni nei metodi produttivi, nelle tecnologie, negli ingredienti, spesso dettate dalle esigenze di gelatieri. Il gelato mantecato espresso è una di queste innovazioni.

È fresco, soffice, leggero, grazie alla maggiore presenza di aria. Richiede meno attrezzature, macchine più piccole e meno costose. È adatto a chi non vuole offrire un'ampia gamma di gusti, focalizzandosi su quelli più tradizionali e facili da vendere.





il gelato del goloso
ARTIGIANALE

Grazie all'attrezzatura fornita in comodato gratuito, il gelato viene erogato direttamente nel cono o nella coppetta con il sistema automatico a pressione one-shot.



500100
ESPRESSO PANNA

16 pz | 90 gr.



500102
**ESPRESSO PANNA
VAR. CIOCCOLATO**

16 pz | 90 gr.



500108
**ESPRESSO PANNA
VAR. AMARENA**

16 pz | 90 gr.



500105
**ESPRESSO YOGURT
VAR. FRUTTI DI BOSCO**

16 pz | 90 gr.



500109
ESPRESSO PISTACCHIO

16 pz | 90 gr.



500115
ESPRESSO NOCCIOLA

16 pz | 90 gr.



500116
ESPRESSO PUFFO

16 pz | 90 gr.





il gelato del goloso

ARTIGIANALE

Le **COPPETTE**
del goloso

PRATICHE E GOLOSE

È soffice e cremoso, ed è ideale per chi vuole un prodotto artigianale ma non può inserire una vetrina nel proprio locale.

Il nostro gelato artigianale italiano si è sempre contraddistinto per l'utilizzo di materie prime nobili di altissima qualità.

Il nostro gelato mantecato in coppetta è un prodotto versatile per soddisfare le tue esigenze, dalla coppetta per i bimbi all'utilizzo per gli affogati.

È fresco, soffice, leggero e goloso. È adatto a chi non vuole offrire un'ampia gamma di gusti, focalizzandosi su quelli più tradizionali e facili da vendere.



500089004

PANNA

16 pz | 85 gr.



500089002

PANNA VARIEGATO CACAO

16 pz | 85 gr.



500089006

PANNA VARIEGATO AMARENA

16 pz | 85 gr.



500089003

CAFFÈ

16 pz | 85 gr.



500803
CONO GOAL

160 pz.



500801
CONO GIGANTE

432 pz.



500802
COPPA TRONCA

252 pz.



500805
CONCHIGLIA PICCOLA

144 pz.



500820
VENTAGLI

240 pz.



500815
SIGARETTE

264 pz.



500837
TERMOS 1000CC

25 pz.



500838
TERMOS 500CC

25 pz.



500828
CUCCHIAINI

1 kg.



500831
COPPETTE PER EXPRESS 100CC

100 pz.



500833
COPPETTE PICCOLE 130CC

100 pz.



500832
COPPETTE MEDIE 200CC

100 pz.



50082507/508/509/502/501/503/504/506

TOPPING VANIGLIA, CAFFÈ, MENTA, CACAO, CARMELLO, FRAGOLA, AMARENA, FRUTTI DI BOSCO

1 kg.

Spray PANNA

Tritato e Cubo GHIACCIO e Cubo



500600
PANNA DEBIC
700 ml.



500310
GHIACCIO CUBETTI 2KG
6 pz.



500311
GHIACCIO TRITATO 2KG
6 pz.



500312
GHIACCIO BALLS 1KG
12 pz.



FROZEN



SORBETTI E GRANITE

Il modo più morbido e gustoso per assaporare al meglio la qualità del gelato Sammontana. La possibilità di offrire ai vostri clienti in qualunque momento della giornata, anche dopo un veloce pasto, un vellutato e piacevole momento di freschezza. Un'occasione in più per sollecitare i desideri dei clienti.



G0634
COMODA E PRONTA LIMONE

2,7 kg.



G0633
COMODA E PRONTA CAFFÈ

2,7 kg.



G0640
COMODA E PRONTA VANIGLIA

2,7 kg.



500750
SGROPPINO LIMONE

1 l.



500853
EROGATORE PER MASTER

1 pz.



500850
CANNUCCE PER GRANITA

1000 pz.



500851
BICCHIERE DI CARTA

100 pz.



GF001
BASE PER GRANITA 7KG

neutra



GF003/004/005/006/007/008/009
MASTER BOTTIGLIA 750ML

arancia / fragola / amarena / limone / menta / cola / anguria



FROZEN

Smoothie

SMOOTHIE

La linea di Smoothie Del Monte, dissetanti e ideali in qualunque momento della giornata! 6 ricette dai colori sorprendenti, dai gusti più classici a quelli più innovativi e ricercati per rispondere alle tendenze di consumo attuali.

La frutta è selezionata con cura, utilizzando solo i pezzi migliori al fine di garantire la massima qualità e freschezza del prodotto.

Si congela seguendo il metodo IQF (Individual-Quick-Freezing),

ovvero Surgelazione Rapida e Individuale. Con questa tecnologia il freddo penetra rapidamente perchè ogni porzione di prodotto viene surgelata singolarmente.

È il metodo più veloce di congelazione e consente alla frutta di mantenere invariate le proprietà. Busta monodose da 150 g di frutta congelata già sbucciata e tagliata.

Pronta all'uso per essere frullata nel blender con 200 ml di succo di mela.



IL BLENDER

Per una preparazione in soli 45 secondi di uno smoothie rinfrescante, sfizioso e caratterizzato dalla bontà della frutta fresca.



FL1020015
SUCCO MELA SQUARE

1 lt.



5020
FRAGOLA / BANANA

18 pz. | 150 gr.



5023
MANGO / LAMPONE

18 pz. | 150 gr.



5021
MELONE / KIWI / ANANAS / MANGO

18 pz. | 150 gr.



5027
PAPAYA / MANGO / ANANAS

18 pz. | 150 gr.



5030
COCCO / MANGO / BANANA / ANANAS

18 pz. | 150 gr.



5024
BANANA / RIBES / MIRTILLO / CILIEGIA

18 pz. | 150 gr.



5026
FRAGOLA / MORA / LAMPONE

18 pz. | 150 gr.



+



+



=



versare 200 ml.
nel bicchiere del fullatore*
di succo mela

aggiungere
prodotto congelato
1 busta 150g di frutta

frullare
per 30 secondi

servire



La storia di un sorriso

'40



Inizia la storia di Sammontana

Romeo Bagnoli, padre di sei figli, per provvedere alla numerosa famiglia acquista la latteria Sammontana, in Via del Giglio a Empoli.

La latteria si chiama come la fattoria da cui prende il latte.

1946



Nasce il gelato Sammontana

Renzo, il figlio maggiore di Romeo, trasforma la latteria in un Bar - Gelateria. Apprende le prime nozioni sul gelato e diventa un vero artista del palato.

Inizia così la produzione del gelato Sammontana.

1955



Da bar-gelateria a laboratorio artigianale

Le vendite del gelato aumentano.

Renzo e il fratello Sergio cominciano a commercializzarlo fuori da Empoli e ideano un barattolo in latta da 6 litri per trasportarlo. La gelateria diventa così un vero e proprio laboratorio artigianale. Viene avviata la produzione dei gelati mondose.

1957



Il claim "Gelati All'Italiana"

Renzo sceglie uno slogan che contiene il lampo di genio delle cose più semplici e immediate: "Gelati all'italiana", per distinguere il suo **gelato dall'icecream diffuso in Italia dai soldati americani**, durante e dopo la Seconda Guerra Mondiale.

1959



Sammontana lancia sul mercato Barattolino

Nasce il mitico Barattolino, ancora oggi prodotto icona di Sammontana.

Un gelato mantecato di carattere tradizionale preconfezionato, nella quantità ideale per un consumo familiare.

1960



Da laboratorio ad azienda

Le richieste continuano ad aumentare oltrepassando i confini toscani.

Sono gli anni del grande salto imprenditoriale. Renzo con i fratelli Sergio e Lorianò, inaugurano lo stabilimento produttivo di Empoli, tutt'ora sede dell'azienda Sammontana.



1980



Il cono che fa “slurp”

Milton Glaser, autore di immagini di culto conosciute in tutto il mondo – come I LOVE NY –, **crea il nuovo logo di Sammontana**: il cono che fa slurp, ancora oggi l’emblema riconoscibile dell’azienda.

1988



Nasce Il Pasticcere. Inizia il rito della colazione al bar

Dall’acquisto di un laboratorio di **prodotti da forno congelati comincia l’avventura de Il Pasticcere**, la cui lievitazione è a base di “pasta madre”.

Anche questo nuovo inizio è contrassegnato dall’innovazione: il croissant è già lievitato e il barista deve semplicemente cuocerlo.

2008



L’acquisizione di GranMilano

L’acquisizione di GranMilano (e dei suoi marchi Sanson, Tre Marie e Mongelo) **proietta Sammontana tra le prime cento aziende agroalimentari italiane** e la posiziona ai vertici del mercato italiano dei gelati industriali, accanto alle grandi multinazionali del freddo.

2009



Tre Marie guida la crescita della pasticceria surgelata

Nelle mani della nuova proprietà, Tre Marie conosce una rinnovata spinta come **marca leader della pasticceria surgelata** permettendo a Sammontana di decretare la sua leadership con la prima e la seconda marca del mercato: Tre Marie e Il Pasticcere.

2013



Sammontana leader del freddo nel fuori casa

Per focalizzarsi sul proprio core business e perseguire gli obiettivi strategici, Sammontana cede il business delle ricorrenze di Tre Marie, confermando la leadership del freddo nel fuori casa. **Inizia così un nuovo percorso per l’azienda** che le permette il consolidamento della sua leadership nella catena del freddo.

2016



L’accordo con il Ministero dell’Ambiente, la svolta nella consapevolezza ambientale

Sammontana consolida il proprio percorso verso **la sostenibilità ambientale, firmando un Accordo Volontario con il Ministero dell’Ambiente** per conoscere, misurare e compensare, prima in Italia nel settore del gelato, l’impronta di carbonio di Barattolino.

2018



Arriva Amando: il gelato buono per le persone e per l’ambiente

Amando è il primo prodotto Sammontana progettato secondo i principi dell’Eco-design e che nasce quindi sostenibile. Diventa il modello guida per tutti i nuovi prodotti Sammontana Italia.

2020



Vicini anche nei cupi momenti del COVID

Sammontana nel pieno della pandemia di Covid-19, con le persone chiuse nelle proprie case in gran parte lontane dai propri affetti, invia un messaggio di resilienza e vicinanza attraverso **la campagna “Solo a un cucchiaino di Distanza”**. La campagna vincerà il premio “The Prize” assegnato da UNACom come miglior Campagna Purpose Driven.

2021



Impresa famiglia. Italia Mondo

Cresce la spinta verso l’internazionalizzazione, nel pieno rispetto delle radici italiane. Identiche sono la passione, l’orgoglio e la determinazione con cui i Bagnoli continuano a produrre il meglio della qualità e del gusto dei “prodotti all’italiana”, che dagli stabilimenti dell’azienda vengono ora e sempre più venduti in tutto il mondo.

2022



L’impegno verso la decarbonizzazione

Sammontana, nell’ambito del proprio percorso in favore della sostenibilità ambientale, rafforza il proprio patto verso un futuro migliore e si impegna a raggiungere una **riduzione delle emissioni di CO2 del 55% entro il 2030**.

2023



Siamo una società Benefit

In qualità di Società Benefit, Sammontana si pone l’obiettivo di operare con profitto per perseguire finalità di beneficio per la società e di **operare in modo responsabile, sostenibile e trasparente nei confronti di persone, territorio, ambiente e altri portatori di interesse**.





DA MAGGIO 2023 SAMMONTANA SPA È DIVENTATA SAMMONTANA SPA SOCIETÀ BENEFIT

CHE COS'È UNA SOCIETÀ BENEFIT?

Si tratta di una nuova forma giuridica di impresa introdotta in Italia nel gennaio 2016 (primo Paese in Europa).

È un modello che impone di inserire nel proprio Statuto, oltre alle finalità di business, anche quelle di **beneficio comune** con l'obiettivo di **creare valore** per la Comunità, le Persone, l'Ambiente e i Territori in maniera **responsabile, sostenibile e trasparente**.

COME SI DIVENTA SOCIETÀ BENEFIT?

Cambiando forma allo statuto della società evidenziando gli impegni a condurre il business secondo un modello responsabile, etico e trasparente.

COSA SIGNIFICA ESSERE SOCIETÀ BENEFIT?

Significa impegnarsi concretamente per avere **un impatto positivo sulla Società e sul Pianeta**. Le Società Benefit sono tenute a redigere ogni anno una relazione d'impatto che delinea i progressi rispetto agli obiettivi specifici inclusi nello Statuto e che descriva sia le azioni svolte sia i piani e gli impegni per il futuro.

PERCHÉ ABBIAMO SCELTO DI ESSERE SOCIETÀ BENEFIT?

Perché crediamo che il nostro ruolo di impresa debba essere anche e soprattutto sociale oltre che economico.

IL NOSTRO IMPEGNO

In qualità di Società Benefit, Sammontana si pone **l'obiettivo di operare con profitto per perseguire finalità di beneficio per la società e di operare in modo responsabile, sostenibile e trasparente nei confronti di persone, territorio, ambiente e altri portatori di interesse**.

Assicurare un futuro all'impresa non può certamente prescindere dalla sostenibilità economica ma questa è vana se non sostenuta da quella ambientale e sociale. Essere società benefit è un percorso fatto di impegni quotidiani, impegni verso i quali lo sforzo di Sammontana è un piccolo ingranaggio che, per funzionare e portare risultati concreti, necessita del supporto e della collaborazione di tutti, nella consapevolezza che l'impatto positivo può essere massimizzato solo collettivamente".



“ Di questo siamo fatti.
Di cuore e di ragione.
Di storia e di progetti.
Di tradizione e di sviluppo.
Di Lavoro Quotidiano.

Così intendiamo proseguire nella nostra impresa di fare ogni giorno impresa. ”

Famiglia Bagnoli



DA 70 ANNI IN ITALIA

*Il gelato con
il sorriso dentro*

VISIONE

Portare il Sorriso nella vita di tutte le persone del mondo offrendo loro prodotti appaganti e buoni perché creati con la cura e la passione autenticamente italiane e nel rispetto delle nostre origini.

MISSIONE

Creare prodotti alimentari di alta qualità, ricette pensate per offrire a ciascuno un'esperienza di piacere, interpretando i nuovi stili alimentari. Fare impresa rispettando le nostre radici italiane, la nostra identità, le nostre persone, le nostre comunità e i nostri territori, ricercando il miglioramento continuo del nostro fare e dell'efficienza, senza compromessi. Essere portatori della cultura e dell'Autentico prodotto Italiano, protagonisti delle evoluzioni degli stili, delle forme e delle modalità di fruizione del gusto nel mondo, in quello di oggi e in quello di domani.



LA SOSTENIBILITÀ Sammontana

A partire dal:

2016

- **Accordo volontario**

Sammontana sigla un Accordo volontario all'interno del Programma nazionale per la valutazione dell'impronta ambientale con il Ministero dell'Ambiente, impegnandosi a misurare e, dove possibile, ridurre l'impronta ambientale dei propri prodotti

- **Approccio metodologico**

In collaborazione con Spinlife, spin off dell'Università degli Studi di Padova



2019

- **Indice di circolarità**

Attenzione alla riduzione degli sprechi, sia in termini di materie prime che di materiali di confezionamento

- **100% astucci Multipack in carta riciclata**

- **I luoghi da salvare**

Italia intatta | Tour 2019 | Mario Tozzi

2017

- **Progetto Scuola Green**

Oltre 2.000 scuole elementari coinvolte in tre anni di programma didattico

- **Spiagge pulite**

Oltre 50 spiagge italiane pulite da Legambiente e Sammontana

2018

- **Progettazione**

Un software dedicato stima a monte gli impatti ambientali delle diverse alternative progettuali

- **Lidi Green**

Punti vendita Sammontana selezionati in base a criteri di sostenibilità ambientale:

- Frigoriferi ad alta "efficienza energetica"
- Compensazione gelato venduto durante la stagione

2020

- **Linea Barattolino Delizie e linea Barattolino Specialità**

Prodotte con tappo e fusto in carta certificata FSC®



Il marchio della gestione forestale responsabile

Dal 2020 Sammontana ha scelto di valorizzare l'esperienza e le competenze acquisite nelle azioni a favore della sostenibilità attraverso una strategia misurabile in tre direzioni



SALUTE E BENESSERE

L'essere umano, la sua salute, il diritto al cibo, la sicurezza alimentare e la sua soddisfazione e benessere



FILIERE SOSTENIBILI

Approvvigionamenti di materie prime/materiali con certificazioni di sostenibilità. Rispetto del principio di interdipendenza lungo la catena del valore



AMBIENTE

Riduzione dell'impatto ambientale

2021 ↓

- **Linea Barattolino Classici**

Prodotta con tappo e fusto in carta certificata FSC®

- **Sammontana rinnova**

l'Accordo con il Ministero della Transizione Ecologica

estendendolo all'intera organizzazione



Il marchio della gestione forestale responsabile

2022 ↓

- **Linea Sorbettiera**

Prodotta con oltre il 50% di plastica bio-circolare*

**Plastica bio-circolare: si riferisce a residui e scarti di origine biogenica provenienti da agricoltura, secondo l'approccio mass balance, processo che traccia accuratamente il flusso del materiale bio-circolare. L'approvvigionamento di materie prime bio-circolari nella produzione di plastica, in sostituzione di plastiche di origine fossile, consente di limitare l'impatto ambientale*



- **Regenerative Society Foundation**

Sammontana entra come membro fondatore in RSF, un'organizzazione basata sulla sinergia tra business e scienza, per supportare la transizione verso una società completamente rigenerativa

- **Impatto ambientale dei prodotti**

Sammontana studia l'impatto ambientale del 42% della produzione gelato

- **Energia da fonti rinnovabili con Garanzia d'Origine**

Sammontana acquista il 12% di energia da fonti rinnovabili

2023/24 ↓

- **Compensazione emissioni**

Dal 2016 Sammontana ha compensato più di 180.000 tonnellate di CO₂eq. per le linee Barattolino, Fruttiamo, Amando, Prima Ricetta e GreenGo

- **Impatto ambientale dei prodotti**

Nel 2023 Sammontana conclude gli studi per l'impatto ambientale di tutti i prodotti gelato

- **Energia da fonti rinnovabili con Garanzia d'Origine**

Sammontana aumenta la quota di acquisto di energia elettrica da fonti rinnovabili arrivando a circa il 20% nel 2023 e stimando di arrivare a una quota di circa il 38% nel 2024

- **Decarbonizzazione**

In base alla misurazione delle emissioni dirette di CO₂eq., Sammontana pianifica attività volte a ridurle progressivamente

Le emissioni di CO₂eq dei gelati della linea Amando sono compensate

Le emissioni di CO₂ equivalenti dell'intero ciclo di vita dei prodotti della linea Amando sono compensate annualmente tramite acquisto di crediti di carbonio certificati, che finanziano progetti di riduzione e rimozione della CO₂ in atmosfera su scala globale. Per calcolare le emissioni di CO₂ equivalenti generate nell'intero ciclo di vita dei prodotti della linea Amando, Sammontana effettua annualmente uno studio seguendo la metodologia LCA (Life Cycle Analysis, norma ISO 14044)

- **Filiere materie prime e materiali**

Sammontana prosegue l'impegno nell'approvvigionamento sempre più rispettoso degli impatti sociali, economici ed ambientali

Dal 2024 la linea Amando si impegna a promuovere l'agricoltura sostenibile della filiera della mandorla

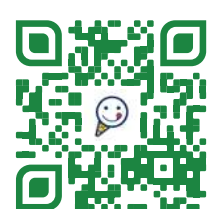

← Inquadra il QR code e scopri di più



SAMMONTANA
 GELATI ALL'ITALIANA
CINQUE STELLE



Firmiamo
 LE MIGLIORI RICETTE
DI GELATO
 CON INGREDIENTI SELEZIONATI,
 DISTINTIVI E CARATTERISTICI.
 PER QUESTO I
nostri coni
MERITANO
CINQUE STELLE



SAMMONTANA
 GELATI ALL'ITALIANA

Barattolino

SAMMONTANA
 GELATI ALL'ITALIANA

Coppa d'Oro

INIMITABILE



LO SAPEVI CHE...?

In 2 anni la gamma Barattolino ha ridotto del 13% le emissioni di CO₂e_q dell'intero ciclo di vita, grazie a nuove ricette e all'utilizzo di carta nella confezione.*





MANGO RAMINGO

A OGNI MORSO:
UNA RIVELAZIONE!



**NUOVA
RICETTA**

MIRTILLO
INASPETTATO

PISTACCHIO
SINCERO

MITICO
CROCCANTINO

COCCO
BELLO

STRACCIATELLA
MAIVISTA

ARACHIDE
SAGACE



DUETTO

SanSoni

**STECCO
BLOCCO**



DONNY

PREZZEMOLO





BARATTOLAME



SUGHI E CONSERVE

Viander Spa si trova a Torgiano, Perugia. Nasce nel 1999, fondata da Antonio Natalini, che oggi guida l'azienda insieme ai suoi figli Giancarlo e Michele. In oltre 20 anni di attività Viander si è guadagnata un ruolo da protagonista nel mondo del food-service e dell'Ho.re.ca. Umbria nel Febbraio 1999, traendo ispirazione dal più antico libro di ricette del XIV secolo: "Le Viander" di Guillaume Tirel detto Taillevent, capo cuoco delle cucine di Francia alla corte di Carlo VI.





930207
ORIGANO

Dosatore 150 gr.



927019
ALICI FILETTI NAZ. 1^ QUALITÀ

4/4 720 gr.



918020
ASPARAGI NATURALI

latta 1/2



922096
BONRÌ MISTO PER RISO FRED.

vaso 1060 gr.



922095
BONRÌ MISTO PER RISO FRED.

vaso 3/1



920005
BRUSCHETTA PRONTA

vaso 1060 gr.



918060
CAPPERI CON GAMB. IN ACETO

vaso 314 gr.



910020
CARCIOFI AL NAT. A SPICCHI

latta 3/1



910070
CARCIOFI ALLA ROMANA

latta 3/1



918090
CAROTE AL NATURALE FILETTI

3/1



918120
CETRIOLI IN AGROLDOLCE

latta 5/1



918125
CETRIOLINI IN ACETO

latta 5/1



918140
CIPOLLE BIANCHE FETTE NAT.

latta 3/1



918155
CIPOLLE R. DI TROPEA IN ACETO

latta 3/1



918175
CIPOLLINE BOR. AGROLDOLCE

latta 3/1



918200
CIPOLLINE PERLINE ACETO

latta 3/1



918201
CIPOLLINE PERLINE IN ACETO

vaso 1700 gr.



918210
CRAUTI NATURALI

latta 1/1



918030
BARBABIETOLE ROSSE AGRODOL.

latta 3/1



915020
CREMA AI FORMAGGI

latta 1/2



915014
CREMA PATÈ OLIVE VERDI

vaso 1060 gr.



915013
CREMA PATÈ OLIVE NERE

vaso 1060 gr.



915040
CREMA ASPARAGI

vaso 580 gr.



915050
CREMA CARCIOFI

vaso 580 gr.



915095
CREMA PORCINI

vaso 580 gr.



918220
CUORI DI PALMA (PALMITO)

latta 1/1



918240
FAGIOLI BIANCHI SP. NAT.

latta 3/1



918270
FAGIOLI CORONA GIGA. NAT.

latta 3/1



918265
FAGIOLI CANNELLINI NAT.

latta 3/1



922161
FAGIOLI BORLOTTI NAT.

latta 3/1



905053
FUNGHI CHAMP. INTERI OLIO

1700 gr.



905086
FUNGHI CHAMP. TRIF. OLIO

latta 3/1



905020
FUNGHI CHAMPIGNON FETTE

3/1



905350
FUNGHI PORCINI TRIFOLATI

latta 1/1



918350
GIARDINIERA ACETO 1^A QUAL.

latta 5/1



918003
GERMOGLI DI SOIA

3/1



922054
GRAN BUFFET PRIMAVERA

latta 3/1



922075
GRAN BUFFET RUSTICHELLO

latta 2/1



922050
GRAN BUFFET ALLA ZINGARA

latta 3/1



918360
INSALATINA ACETO DI VINO

latta 3/1



918380
MAIS DOLCE NATURALE

latta 1/2



918426
PEPERONI A FILETTI

vaso 1700 gr.



918415
PEPERONI LOMBARDI

latta 5/1



918011
SPIEDINI ORTO (BANDERILLAS)

vaso 2000 gr.



922161
WURTSEL PEZZI 8

vaso 1040 gr.



908025
OLIVE GOURMET NERE GIGA.

busta kg. 1,5



908035
OLIVE GOURMET VERDI GIGA.

busta kg. 1,5



908091
OLIVE VERDI GIGANTI

latta 5/1



908005
OLIVE VERDI INTERE

24/26 vaso 1700 gr.



908011
OLIVE VERDI GIGANTI

vaso 1700 gr.



908110
OLIVE VERDI SP. INT. GIGANTI

10/12 latta 3/1



908115
OLIVE VERDI SP. INT. M.

18/22 latta 3/1



908061
OLIVE VERDI INTERE

18/22 latta 5/1



908100
OLIVE VERDI SP. DEN.

28/32 latta 3/1



908070
OLIVE NERE SP. DEN.

28/32 latta 3/1



901001
TONNO SPAGNA

latta 12x80 gr.



901007
TONNO SENEGAL

latta 1/1



920190
RAGÙ DI CINGHIALE

latta 1/2



920205
RAGÙ DI LEPRE

latta 1/2



920180
RAGÙ DI CERVO

latta 1/2



915157
SALSA TOAST

vaso 1700 gr.



936080
GRISSINI TORINESI

240x12 gr.



935070
FETTE BISCOTTATE HOTEL

4x52 gr.



935106
CEREALI PRIMA COLAZIONE

Muesli 16x1000 gr.



935031
CONF. MONO. ALBICOCCA

168x25 gr.



935033
CONF. MONO. CILIEGIA

168x25 gr.



935034
CONF. MONO. FRAGOLA

168x25 gr.



935037
CONF. MONODOSE PESCA

168x25 gr.



CONDIMENTI



Monodose MONODOSE



930111
MAIONESE MONODOSE

200x15 gr.



930112
SENAPE MONODOSE

200x15 gr.



930113
KETCHUP MONODOSE

200x15 gr.



909040
**OLIO
EXTRA VERGINE
D'OLIVA**

250x12 gr.



909031
**ACETO BALSAM.
MONODOSE**

250x6 gr.



920035 / 920037
**SALE
MONODOSE**

Busta 2 gr x pz1825 / gr. 2 x pz. 500



909042
**OLIO
EXTRA VERGINE
D'OLIVA**

100x10 ml.



909030
**ACETO DI VINO
MONODOSE**

250x5ml



920031
**PEPE
MONODOSE**

busta gr. 2 x pz. 1000

CONDIMENTI



Salse

SALSE



930100
**MAIONESE
PROFESSIONALE**
secchiello 5 kg.



930101
**MAIONESE
GASTRONOMICA**
secchiello 5 kg.



930119
**MAIONESE
LEGGERA
20%OLIO**
secchiello 5 kg.



930102
**MAIONESE
DA TAVOLA**
vaso vetro 1000 ml.



930104
KETCHUP
secchiello 5 kg.



930103
**MAIONESE
GASTRONOMICA**
squeezer 1000 ml.



930107
**SENAPE
MEDIO FORTE**
squeezer 1000 ml.



930105
KETCHUP
squeezer 1000 ml.





930108
SALSA TONNATA
vaso vetro 1000 ml.



930115
SALSA TONNATA
squeezer 1000 ml.



930110
SALSA TARTARA
vaso vetro 1000 ml.



930109
SALSA ROSA
vaso vetro 1000 ml.



930116
SALSA ROSA
squeezer 1000 ml.



930118
SALSA BARBECUE
squeezer 1,2 kg.



915315
SALSA BOSCAIOLA
squeezer 1000 ml.



950257
**SALSA DIP
PICCANTE**
vaso 1,05 kg.

CONDIMENTI

POLPA DI POMODORO



903143
**POMODORO POLPA
PEZZETTONI**
latta 3/1



903041
**POMODORO POLPA
FINE**
latta 5/1



903053
**POMODORI PELATI
EXTRA**
latta 3/1



960000
**POLPA DI POMODORO
FINE**
latta 5 l.

PASTA



Pasta Secca PASTA SECCA

Barilla è un'azienda italiana, ancora oggi di proprietà della famiglia che l'ha fondata nel 1877. È la principale azienda italiana nella produzione di pasta di semola e sughi pronti. È inoltre un leader globale, presente in oltre 100 paesi. L'azienda è simbolo nel mondo dell'eccellenza nell'ambito agroalimentare.





770101
SPAGHETTI

12x1 kg.



770102
BAVETTE

12x1 kg.



770103
SEDANINI

9x1 kg.



770104
FARFALLE

10x1 kg.



770106
MEZZE PENNE

12x1 kg.



770107
PENNETTE RIGATE

12x1 kg.



770108
PENNE RIGATE

12x1 kg.



770109
TORTIGLIONI

10x1 kg.



770110
FUSILLI

10x1 kg.



770111
CASARECCE

9x1 kg.



770114
GNOCCHETTI SARDI

9x1 kg.



770200
TAGLIATELLE

6x1 kg.



770201
PAPPARDELLE

6x1 kg.



300735
RISO CARNAROLI

10x1 kg.



OLIO

OLIO EXTRA VERGINE E SEMI



930017
**OLIO EXTRA VERGINE
OLIVA BOTT.**

bottiglia vetro 1 l.



930018
**OLIO EXTRA VERGINE
OLIVA BOTT.**

bottiglia vetro 750 ml.



930019
**OLIO EXTRA VERGINE
OLIVA SELEZIONE**

bottiglia vetro 500 ml.



930016
**OLIO EXTRA VERGINE
OLIVA LATTINA**

latta 5 l.



930020
**OLIO DI SEMI
DI GIRASOLE**

latta 5 l.



930021
**OLIO TOP 100%
GIRASOLE**

latta 20 l.





BEVERAGE

ACQUA E BIBITE

Acqua e Bibite

Il mondo "Beverage" è un mondo per noi a completamento della vasta gamma di prodotti che abbiamo in assortimento. Succhi, bibite, amari, acqua, vini, birre, liquori e aperitivi per offrire un servizio a 360° alla nostra clientela. Trattiamo anche in questo settore marchi e prodotti leader del mercato e dall'indiscussa qualità che non hanno perciò bisogno di grandi presentazioni.



SC5031
ACQUA NATURALE 50 CL

50 cl. | 24 pz



SC0926
ACQUA NATURALE 1 L

1 l. | 12 pz



SC5520
ACQUA NATURALE

1,5 l. | 6 pz



SC5011
ACQUA FRIZZANTE 50 CL

50 cl. | 24 pz



SC0927
ACQUA FRIZZANTE 1 L

1 l. | 12 pz



SC5560
ACQUA FRIZZANTE

1,5 l. | 6 pz



SC6705
GINGER

1,5 l. | 6 pz



SC6701
ARANCIATA

1,5 l. | 6 pz



SC6700
GAZZOSA

1,5 l. | 6 pz



SC6702
SPUMA NERA

1,5 l. | 6 pz



101060
COCA COLA

1,5 l. | 6 pz



102060
FANTA

1,5 l. | 6 pz



118061
LEMONSODA

1,25 l. | 6 pz



125060
SCHWEPES TONICA

1 l. | 6 pz



203060
ESTATHE LIMONE

1,5 l. | 6 pz



203061
ESTATHE PESCA

1,5 l. | 6 pz



LASANBENEDETTO150
MY SIFONE SODA

1,5 l. | 6 pz





SC6002
BELTÈ LIMONE

33 cl. | 24 pz



SC6003
BELTÈ PESCA

33 cl. | 24 pz



SC6001
BELTÈ PESCA

12x50 cl.



SC6000
BELTÈ LIMONE

12x50 cl.



Z21031
GATORADE LIMONE

50 cl. | 12 pz.



Z21030
GATORADE ARANCIA

50 cl. | 12 pz.



Z21032
GATORADE ARANCIA ROSSA

50 cl. | 12 pz.



Z21036
GATORADE COOL BLUE

50 cl. | 12 pz.



ZIBIBLAT031
ESTATHÈ PESCA LATTINA

33 cl. | 24 pz



ZIBIBPL019
ESTATHÈ PESCA BICCHIERE

20 cl. | 24 X 3 pz



ZIBIBLAT030
ESTATHÈ LIMONE LATTINA

33 cl. | 24 pz



ZIBIBPL018
ESTATHÈ LIMONE BICCHIERE

20 cl. | 24 X 3 pz



ZIBIBLAT001
COCA COLA

33 cl. | 24 pz



ZIBIBLAT016
COCA COLA ZERO

33 cl. | 24 pz



ZIBIBLAT017
SPRITE

33 cl. | 24 pz



ZIBIBLAT019
FANTA

33 cl. | 24 pz



ZIBIBLAT025
LEMONSODA

33 cl. | 24 pz



ZIBIBLAT026
ORANSODA

33 cl. | 24 pz



ZIBIBLAT020
ARANCIATA DOLCE

33 cl. | 24 pz



ZIBIBLAT021
ARANCIATA AMARA

33 cl. | 24 pz



ZIBIBLAT022
CHINOTTO

33 cl. | 24 pz



105020
KINLEY TONICA

20 cl. | 24 pz.



167096
GINGER BEER

20 cl. | 24 pz.



160001
CEDRATA TASSONI

18 cl. | 25 pz.



ZENERE001
RED BULL

25 cl. | 24 pz



ZIBIBLAT028
SCHWEPPE'S TONICA

33 cl. | 24 pz





BOB

GUSTI STREPITOSI! 4 RICETTE UNICHE

FRUTTI
TROPICALI



BUBBLE TEA
TROPICAL MIX

**Tè nero
ai frutti
tropicali
con palline
al mango**

LIME
E MELA



BUBBLE TEA
BLUE LIME

**Tè verde
al limone
e mela
con palline
al lime**

FRUTTI
DI BOSCO



BUBBLE TEA
FRUIT BERRY

**Tè nero
ai frutti
di bosco
con palline
al mirtillo**

PESCA
E LITCHI



BUBBLE TEA
SAKURA PEACH

**Tè verde
alla pesca
e litchi
con palline
all'uva**

GIMI0431
**BUBBLE TEA
BOB TROPICAL MIX**

9 pz.

GIMI0429
**BUBBLE TEA
BOB BLUE LIME**

9 pz.

GIMI0432
**BUBBLE TEA
BOB FRUIT BERRY**

9 pz.

GIMI0430
**BUBBLE TEA
BOB SAKURA PEACH**

9 pz.

BEVERAGE

SUCCHI DI FRUTTA



TRI1240
SUCCO PERA
20 cl. | 24 pz



TRI1239
SUCCO MIRTILLO
20 cl. | 24 pz



TRI1241
SUCCO PESCA
20 cl. | 24 pz



TRI1233
SUCCO ACE
20 cl. | 24 pz



TRI1236
SUCCO ARANCIA
20 cl. | 24 pz



TRI1243
SUCCO POMPELMO
20 cl. | 24 pz



TRI1234
SUCCO ALBICOCCA
20 cl. | 24 pz



TRI1235
SUCCO ANANAS
20 cl. | 24 pz



BEVERAGE

BIRRE IN BOTTIGLIA

ZBIRBOT01
BECK'S

33 cl. | 24 pz



ZBIRBOT54
HEINEKEN

33 cl. | 24 pz



ZBIRBOT02
CERES STRONG

33 cl. | 24 pz



TRIO308
BITBURGER PILS

33 cl. | 24 pz



ZBIRBOT03
CORONA EXTRA

33 cl. | 24 pz



Z30273
ZBIRBOT43
MORETTI

33 cl. | 24 pz
66cl. | 15 pz



ZBIRBOT09
TENNENT'S SUPER

33 cl. | 24 pz



ZBIRBOT10
**ICHNUSA
NON FILTRATA**

33 cl. | 24 pz



ZBIRBOT12
**FRANZISKAINER
HEFE-WEISS**

50 cl. | 20 pz



313030
PORETTI 3 LUPPOLI

66 cl. | 15 pz



CARB03DA / 311260
**PORETTI 4 LUPPOLI /
NON FILTRATA**

33 cl. | 24 pz



315061
**PORETTI 6 LUPPOLI
ROSSA**

33 cl. | 24 pz



315083
**PORETTI 9 LUPPOLI
AMERICAN IPA**

33 cl. | 24 pz



CAR48471
**GRIMBERGEN
BLONDE**

33 cl. | 24 pz



CAR48472
**GRIMBERGEN
DOUBLE**

33 cl. | 24 pz



CAR48473
**GRIMBERGEN
BLANCHE**

33 cl. | 24 pz



BEVERAGE

Vini

VINI

AZ0024
**PINOT
GRIGIODOC
GARDA**

75 cl. | 12 pz.



AZ0008
**PINOT
BIANCO IGT
VENETO**

75 cl. | 12 pz.



TRI3641
**LUGANA
DOC
SORAIGHE**

75 cl. | 6 pz.



AZ0037
**LUGANA
DOC
CA' DEI FRATI**

50 cl. | 6 pz.



AZ0004
**BRUMANO
BIANCO
FERMO**

75 cl. | 12 pz



AZ0010
**CUSTOZA
BIANCO
DOC**

75 cl. | 12 pz



AZ0016
**BIANCO
RUSTICO
FRIZZANTE**

75 cl. | 6 pz



AZ0001
**MOSCATO
SPUMANTE
ARIONE**

75 cl. | 6 pz



AZ0038
**SPUMANTE
TEA D'ORO**

75 cl. | 6 pz



AZ0002
**PROSECCO
BOSCO DEI CIRMIOLI**

75 cl. | 6 pz



SAP15166
**SANTERO
EXTRA DRY**

75 cl. | 6 pz



AZ0025
**CHIANTI
LA CANVA**

75 cl. | 12 pz



AZ0023
**NEGROAMARO
SALENTO**

75 cl. | 6 pz



AZ0031
**MORELLINO
AIA VECCHIA**

75 cl. | 6 pz



AZ0005
**BRUMANO
ROSSO
FERMO**

75 cl. | 6 pz



AZ0011
**BARBERA
DEL PIEMONTE**

75 cl. | 6 pz



AZ0012
**MONTEPULCIANO
D'ABRUZZO**

75 cl. | 6 pz



AZ0013
**NERO
D'AVOLA**

75 cl. | 6 pz





BEVERAGE

Aperitivo

APERITIVO

ZAPEVAP01
CAMPARI SODA

9,8 cl. | 100 pz



ZAPEVAP02
CRODINO

10 cl. | 48 pz



ZAPEVAP05
SAN BITTER

10 cl. | 40 pz



SAP1670
**APERITIVO
SPRITZ**

100 cl.



SAP1668
**SPRITZ ZERO
READY
TO DRINK**

75 cl. | 6 pz



SAP1698
**SPRITZ LATTINA
READY
TO DRINK**

33 cl. | 24 pz



ZAPEAPE01
APEROL

100 cl.



ZAPECAM01
BITTER CAMPARI

100 cl.



ZO0340
MARTINI BIANCO

100 cl.



ZO0339
MARTINI ROSSO

70 cl.



BEVERAGE

Superalcolici

SUPERALCOLICI

907015
**RUM HAVANA
3 ANNI**

70 cl.



907016
**RUM HAVANA
3 ANNI**

100 cl.



907021
**RUM BIANCO
PAMPERO**

100 cl.



910111
**RUM CREOLA
FANTASIA**

100 cl.



ZO0149
**VODKA BIANCA
KEGLEVICH**

100 cl.



ZO0150
**VODKA FRAGOLA
KEGLEVICH**

100 cl.



ZO0151
**VODKA PESCA
KEGLEVICH**

100 cl.



ZO0158
**VODKA MENTA
KEGLEVICH**

100 cl.



916050
**TEQUILA
ESPOLON BLANCO**

70 cl.



916051
**TEQUILA
ESPOLON REPOSATO**

70 cl.



916030
**TEQUILA QUERVO
SILVER**

70 cl.



ZO0145
**PUNCH RHUM
BARBIERI**

100 cl.



ZO0146
**PUNCH ARANCIO
BARBIERI**

100 cl.



ZO0147
**PUNCH MANDARINO
BARBIERI**

100 cl.



906090
**GIN MALFY
ORIGINAL**

70 cl.



906091
**GIN MALFY
LIMONE**

70 cl.



906092
**GIN MALFY
ARANCIA**

70 cl.



906093
**GIN MALFY
ROSA**

70 cl.





AZ0020
**GRAPPA
PER CORREZIONE**

100 cl.



Z00192
**GRAPPA
NARDINI**

100 cl.



Z00193
**GRAPPA NARDINI
RISERVA**

100 cl.



TRI3092
**GRAPPA CULTO
AMARONE
CONFEZIONE TUBO**

70 cl.



TRI3095
**GRAPPA CULTO
BAROLO
CONFEZIONE TUBO**

70 cl.



TRI3093
**GRAPPA CULTO
MOSCATO
CONFEZIONE TUBO**

70 cl.



TRI3094
**GRAPPA CULTO
GEWURZTRAMINER
CONFEZIONE TUBO**

70 cl.



TRI3100
**GRAPPA BIANCA
ECCELSA NOVELLA**

70 cl.



TRI3101
**GRAPPA GIALLA
ECCELSA INVECCHIATA**

70 cl.



Z01522
**LIMONCELLO
CAPRI**

100 cl.



Z00157
**VECCHIA ROMAGNA
ETICHETTA NERA**

70 cl.



Z00143
VECCHIA ROMAGNA

70 cl.



Z00155
**BRANCA
STRAVECCHIO**

100 cl.



Z00112
FERNET BRANCA

100 cl.



Z00111
BRANCA MENTA

100 cl.



Z01698
**SAMBUCA
MOLINARI**

100 cl.



Z00109
**AMARO
MONTENEGRO**

70 cl.



Z00153
BRAULIO

100 cl.



Z00154
RAMAZZOTTI
100 cl.



Z00110
AMARO AVERNA
100 cl.



Z00156
MARZADRO ANIMA NERA
70 cl.



Z00668
BAILEY'S
100 cl.



TRI3023
VECCHIO AMARO DEL CAPO
70 cl.



Z00072
JAGERMEISTER
100 cl.



Z00205
GIN GORDON
100 cl.



910031
AMARETTO DI SARONNO
100 cl.



Z00152
JACK DANIEL'S
100 cl.



905100
WHISKY LAGAVULIN
100 cl.



905002
WHISKY BALLANTINES
100 cl.



905010
WHISKY GLEN GRANT
70 cl.



904001
AMARO CYNAR
100 cl.



910006
LIQUORE CACHACA
100 cl.



903017
BRANDY CARLOS I
70 cl.



910087
LIQUORE MIDORI
100 cl.



910045
LIQUORE COINTREAU
70 cl.





DOLCIUMI

Caramelle, Cioccolati E RICORRENZE











MATERIALE VARIO

No Food
NO FOOD





LALEONE 220
**INSALATIERA CON COPERCHIO
1000ML**

24 pz.



LADAMPE140
**INSALTIERA
CON COPERCHIO 1360ML**

15 pz.



LALEONE210
**INSALATIERA QUADRATA
17X17X7,5 - 1400ML**

24 pz.



LAPIAT17
**PIATTO TONDO
Ø17**

50 pz.



LAPIAT22
**PIATTO TONDO
Ø22**

50 pz.



LAFON600ML
**PIATTO FONDO
IN CELLULOSA 600ML**

50 pz.



LAUSOBIO260
**PIATTO OVALE
IN POLPA
DI CELLULOSA**

50 pz.



LAUSOBIO100
**PIATTO PIZZA
COMPOSTABILE
BIO Ø32**

25 pz.



KIPACK100
**VASCHETTA
ALLUMINIO
14X11**

100 pz.



USOBIBO100
**BIS POSATE LEAN PLA
+ TOVAGLIOLO 2V**

500 pz.

LABIBO205
**VASCHETTA PORTA
PATATINE POLPA CELL.**

50 pz.



X0108
**BICCHIERE
CARTA
CAFFÈ 10CL**

50 pz.



500858
**BICCHIERE CARTA
CAFFÈ 10CL
+ COPERCHIO**

100 pz.



500859
**BICCHIERE CARTA
CAPPUCCIO 40CL
+ COPERCHIO**

100 pz.



TRI3192
**BICCHIERE PLASTICA
500CC**

50 pz.



LABICC400
**BICCHIERI TRASP.400ML
(TACCA 300ML)**

100 cl.



LABICC300
**BICCHIERI TRASP.250ML
(TACCA 200ML)**

100 cl.





RO017
**CANNUCCE IMBUSTATE BIO
COLORATE**

200 pz.



ALPI120
**CANNUCCE BIO NERE
H13,5 - Ø7**

500 pz.



RO019
**SACCHI PATT.
AZZURRI 50X60**

20 pz.



RO020
**SACCHI PATT.
GIALLI 72X110**

10 pz.



RO023
**SACCHI PATT.
NERI 72X110**

10 pz.



LA001
**SACCHI PATT.
NEUTRO 72X110**

10 pz.



LA002
**SACCHI PATT.
BIO VERDE 70X110**

10 pz.



LA003
**SACCHI PATT.
BIO VERDE 70X70**

20 pz.



RO011
RAPID ALLUMINIO

125 mt.



RO012
RAPID PELLICOLA

300 mt.



LAPACK110
CARTA FORNO H33

50 mt.



1841S
SANIALC ULTRA

750 ml.



1866S
CRYSTAL VETRI

750 ml.



LAREFLEXX
105 / 110 / 115
**GUANTI NITRILE
TAGLIA M / L / XL**

100 pz.



4006
**SAPONE LIQUIDO
GREEN POWER**

5 kg.



1033
SANI GEL

600 ml.



1821S
MULTIACT CUCINA

750 ml.



ES400080RO
TOVAGLIOLO 25X25 2V. ROSSO

100 pz. x 48



ES400080GI
TOVAGLIOLO 25X25 2V. GIALLO

100 pz. x 48



ES600600
TOVAGLIOLO 33X33 2V

50 pz. x 36



ES750700
TOVAGLIOLO 38X38 2V

50 pz. x 42



ES920100A1
**BUSTA CON TOVAGLIOLO
DEC. "SERENA" A1**

500 pz.



ES920400
**BUSTA CARTA PAGLIA
NEUTRA**

400 pz.

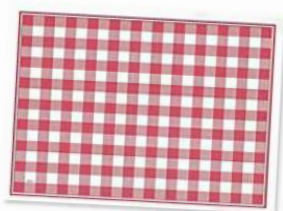

ES300210T16R
**TOVAGLIETTE 30X40
DEC. SCOZZESE ROSSO T1**

500 pz. x 5



ES300126
**TOVAGLIETTE 30X40
CARTA PAGLIA**

500 pz. x 3



ES300850
**TOVAGLIA ROTOLO
MT 1X50 TIPO R**

1 pz.



ES10103185
ASCIUGAM. INT. Z CELL. 2 V.



ES10106040G
ROTOLO PULITUTTO GOFRATO

Kg. 2,5



ES11117024
**CARTA IGIENICA
NUVOLÌ**

24 pz.



ES10103660
IGIENICA JUMBO CELL. 2 V.

Kg. 1,000



ES10103640
IGIEN. MINIJUMBO CELL. 2 V.

Kg. 0,600



ES11117985
**CARTA IGIENICA CELL.
2 V. INT**

50 pz.

FRESCHI



Salumi GRANDI MARCHI



FL087
COTTO GRAN SAPORE

7,5 kg. circa



FL118
GRANBISCOTTO

7,5 kg. circa



FLQB712
DADINI GRAN COTTO BORGIO

90 gr.



FLLZ806
PANATINE MAIS PROS. COTTO

175 gr.



FLL7110
COTTO ALTA QUALITÀ

busta 100 gr.



FLL7010
CRUDO NOSTRANO

busta 100 gr.



FLL7210
MORTADELLA

busta 100 gr.



FLL7310
SALAME MILANO

busta 100 gr.



FLL7510
COPPA DI PARMA

busta 100 gr.



FL3700
COTTO IL CAMPANONE
7,5 kg. circa



FL3692
COTTO IL CAMPANONE 1/2
3,5 kg. circa



FL3810
PROS. COTTO ALTA QUALITÀ
7,5 kg. circa



FL3622
PROS. COTTO PRAGA 1/2
3 kg. circa



FL3461
PROS. COTTO 10X10 PESO FISSO
3 kg.



FL5630
TENERONE PROS. COTTO
150 gr.



FL3494
MORTADELLA C. PISTACCHI 1/2
6,5 kg. circa



FL4436
PROS. COTTO LIBERAMENTE
busta 110 gr.



FL4440
MORTADELLA LIBERAMENTE
busta 110 gr.



FL4290
PROS. CRUDO LIBERAMENTE
busta 80 gr.



FL5090
PROS. CRUDO BORGO EMILIA ES.
6 kg.



85857
PROSCIUTTO CRUDO 1/4
1,5 kg. circa



FL4551
SPECK
busta 100 gr.



88105
SPECK MONTAGNA 1/4
1,2 kg.



FL0416
SPECK MONTAGNA GRAN RESA
2,5 kg.



FL5741
STINCO COLLE EMILIA

550 gr.



FL5742
COTECHINO COLLE EMILIA

500 gr.



FL5743
ZAMPONE COLLE EMILIA

900 gr.



FL5801
GIRAVOLTE VERDURE/PROVOLA

170 gr.



FL5222
SALAME MILANO 1/2

1 kg. circa



FL3244
CACCIATORINO DOP

175 gr. circa



FL4441
TACCHINO LIBERAMENTE

busta 110 gr.



FL3505
PORCHETTA TRANCIO

2 kg. circa



FL3246
SPIANATA CALABRA

1,5 kg. circa



FL0515
CULATTA

3 kg. circa



FL5210
COPPA STAGIONATA

1 kg. circa



FL4537
GIARDINIERA CAPRICCIOSA

3 kg. circa



FL5916
SPECK A CUBETTI

50 gr. | 2 pz.



FL5988
PANC. CUBETTI AFFUMICATA

110 gr.



FL5987
PANCETTA A CUBETTI DOLCE

110 gr.



FL2039
WURSTEL SUINO

100 gr. | 4 pz.



FL2259
WURSTEL POLLO

100 gr. | 4 pz.



FL3149
WURSTEL SUINO E POLLO

100 gr. | 4 pz.



FL2040
WURSTEL SUINO

250 gr. | 3 pz.



FL2260
WURSTEL POLLO

250 gr. | 3 pz.



FL3162
WURSTEL SUINO E POLLO

250 gr. | 3 pz.



FL4830
WURSTEL WEISSWURST

200 gr.



FL3165
WURSTEL SERVELADE

200 gr.



88100
WURSTEL DOLOMITI

250 gr. | 3 pz.



85365
IL GOLFETTA

3 kg. circa



85396
MORTADELLA PURO SUINO

4 kg. circa

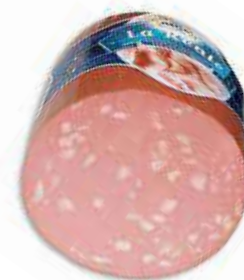

88181
CRUDO NOSTRANO DISSO.

6 kg. circa



88182
CRUDO PARMA DISSO.

6 kg. circa



88183
CRUDO NOSTRANO C.OSSO

7 kg. circa



85858
PROS. COTTO NOVELLO 1/4

1,5 kg. circa



85950
CRUDO MATTONELLA 1/2

1,5 kg. circa



85852
SPIANATA PICCANTE

1 kg. circa



88031
SALAME NOSTRANO

1 kg. circa



88048
SALAME MILANO 1/2

1 kg. circa



88061
COPPA

1 kg. circa



85851
LARDO PANCETTATO

4 kg. circa



88063
PANCETTA SUPERCOPPATA

2,5 kg. circa



85870
PANCETTA ROTOLO 1/2

2 kg. circa



88064
PANCETTA RUSTICA

1,8 kg. circa



88065
PANCETTA NOSTRANA RISERVA

2,5 kg. circa



88034
PANCETTA TESA STRAPPATA

1,8 kg. circa



88035
PANCETTA TESA AFFUMICATA

1,8 kg. circa



88201
PANCETTA PIACENTINA

5 kg. circa



88040
PASTA SALAME

200 gr. circa



88043
GROPPINO SALSICCIA

1,5 kg. circa



88044
MANTOVANELLE SALAMELLE

1,5 kg. circa



FRESCHI

RIGAMONTI
Qualità dal 1913

Salumi DALLA VALTELLINA



88141
BRESAOLA P.D'ANCA IGP

3 kg. circa



88142
BRESAOLA P.D'ANCA IGP 1/2

1,5 kg. circa



88143
CARPACCIO DI BRESAOLA 1/2

2 kg. circa



88144
BRESAOLA P.D'ANCA STELVIO 1/2

1,5 kg. circa



88146
BRESAOLA P.D'ANCA RISTORO 1/2

1,5 kg. circa



31185
BRESAOLA IGP

70 gr.



88145
PROSC. FIOCCO VALTELLINA

3 kg. circa

FRESCHI

delicatesse®

Di alta Qualità

CARNI LAVORATE

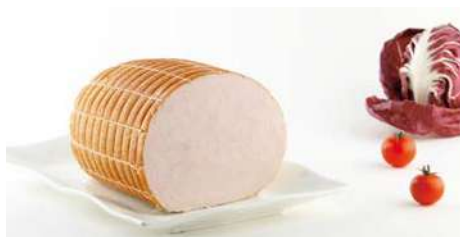

86100
FESA DI TACCHINO
2,5 kg. circa



86103
SOTTO FESA DI MANZO ALL'ING.
2,2 kg. circa



86102
FESA DI MANZO ALL'INGLESE
2 kg. circa



86104
GIRELLO PIEMONTESE
2,5 kg. circa



86116
GIRELLO PER CARPACCIO
2 kg. circa



86105
MANZO PER CARPACCIO

2 kg. circa



86106
ROLL ALLE ERBE C.PANCETTA

3 kg. circa



86130
ROLL ALLE ERBE

3 kg. circa



86127 / 86126
PATÈ DI VITELLO

200 gr. / 1,2 kg. circa



86135
POLLO ROLL PIÙ

3 kg. circa

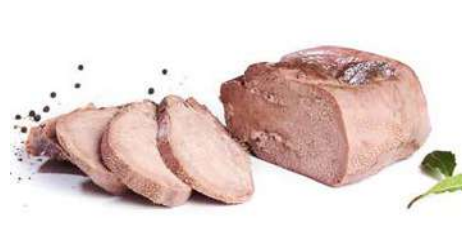

86107
LINGUA BOVINA COTTA

2,5 kg. circa



86117
CIMA GENOVESE CLASSICA

3 kg. circa



86120
NERVETTI INTERI

1,5 kg. circa



86131
MARCHIGIANA

3 kg. circa

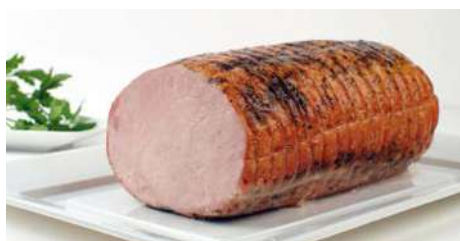

86128
LONZARROSTO

2 kg. circa



86129
P. DI TACCHINO AFFUM. C.PELLE

5 kg. circa

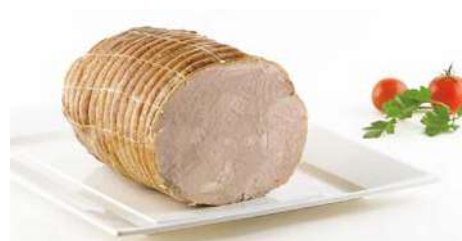

86115
ARROSTO DI VITELLO

2 kg. circa

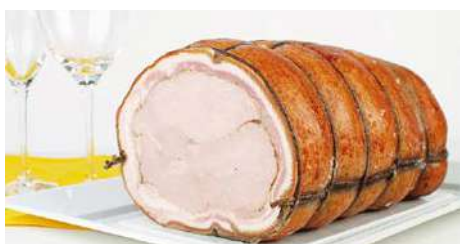

86113
PORCHETTA BRIANZOLA TRANCIO

4 kg. circa



86119 / 86118
F. DI TACCHINO ARROSTO

5 kg. circa / 2,5 kg. circa

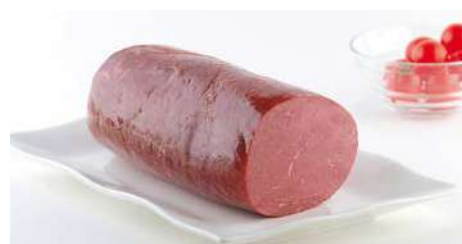

86132
MANZO FUMÈ

2 kg. circa

FRESCHI



Salumi LE ECCELLENZE

La ricerca del gusto, con la qualità italiana.

La qualità è all'origine di tutto, per questo scegliamo solo le eccellenze per i nostri prodotti. Selezioniamo scrupolosamente

ogni singola materia prima che utilizziamo nelle nostre preparazioni

perché riteniamo fortemente che, per offrire il meglio,

dobbiamo pretendere altrettanto dagli ingredienti che compongono i nostri prodotti.





FLBI0155
LUGANICA PASSITA "ASINO"

300 gr. circa



FLBI0783
GROPPINO GHIRLANDINO

300 gr. circa



FLBI0183
GROPPINO PICCANTE

300 gr. circa



FLBI0471
SALAME BACCARÀ

3,5 kg. circa



FLBI1224
WURSTEL NATURALE ARTIG.

150 gr. circa



FLBI0009
CICCIOLI FROLLI

1,2 kg. circa



FLBI0010
COPPA DI TESTA

7 kg. circa



FLBI0195
SOPPRESSA CON FILETTO

2 kg. circa



FLBI0120
SOPPRESSA CON OSSOCOLLO

2 kg. circa



FLBI1258
COPPA DI TESTA MINI

2 kg. circa



FLBI0566
PROS. COTTO TIROLESE

7 kg. circa



FLBI1075
PROS. COTTO TIROLESE 1/2

3,5 kg. circa



FLBI0356
PANC. AFFUMICATA NOSTRANA 1/2
3 kg. circa



FLBI0033
PANC. ARROTOLATA CASALINA
3,5 kg. circa



FLBI0093
PANCETTA COPPATA 1/2
3 kg. circa



FLBI0960
LARDO DI PATANEGRA
2,5 kg. circa



FLBI0745
PANCETTA REGINELLA
1,3 kg. circa



FLBI0312
PANCETTA TESA MONTAGNA
6 kg. circa



FLBI0812
LARDO ARR. MANICA MINI
2 kg. circa



FLBI0050
LARDO ARR. MANICA 1/2
5 kg. circa



FLBI0574
PORCHETTA TOSCANA TRANCIO
5/10 kg. circa



FLBI0096
OSSOCOLLO CASALINO
1,7 kg. circa



FLBI0496
OSSOCOLLO REALE
4 kg. circa



FLBI0824
OSSOCOLLO REALE STAG. 1/2
2 kg. circa



FLBI0193
FILONE DEI DOGI
3 kg. circa



FLBI1033
FILONE DEI DOGI 1/2
1,5 kg. circa



FLBI0279
FILONE DUSTACCO
5 kg. circa



FLBI0321
GUANCIALE DI MONT. STAG.
1,5 kg. circa



FLBI1015
GUANCIALE FILETTATO
2 kg. circa



FLBI0372
SPECK MONTANARO C.FESA
7 kg. circa



FLBI0070
SPECK MONTANARO C.FESA 1/2
3,5 kg. circa



FLBI0301
LARDO LOMBATO STAGIONATO
3 kg. circa



FLBI0062
BOLOGNA ANTICA 1/2
9 kg. circa



FLBI1252
BRESAOLA DI BUFALA 1/2
2,5 kg. circa



FLBI0514
BRESAOLA SOPRANA BOVINA
3 kg. circa



FLBI1359
BRESAOLA ALLA TIROLESE
3,5 kg. circa



FLBI1367
BRESAOLA ALLA TIROLESE 1/2
1,75 kg. circa



FLBI0599
BRESAOLA ROSADA
2,5 kg. circa



FLBI0116
CARNE SALADA
3,5 kg. circa



FLBI1254
CARPACCIO DI BUFALA
3 kg. circa

FRESCHI



LATTICINI

Latte e Formaggi



137000
LATTE INTERO
(FRESCO PIU' GIORNI) 1 l.



FLVG0872
LATTE UHT INTERO
1 l. (CON TAPPO)



FLVG0873
LATTE UHT P.S.
1 l. (CON TAPPO)



FLVG0225
ASIAGO FRESCO DOP



FLVG0281
BRIE FRANCESE FORMA
2 kg. circa



FL0451
MOZZ. ROSELLA ITALIANA
100 gr.



FLVG0448
MOZZARELLA CUBETTATA UE
2500g. vaschetta



FLVG0459
MOZZARELLA JULIENNE UE
2500 gr. vaschetta



FLVG0450
MOZZARELLA PER PIZZA UE
1000 gr. filone



FRESCHI

Formaggi FORMAGGI



FLA220005
FORMAGGINI

140 gr.



85424
EDAMER FETTE

1 kg.



85429
MOZZARELLA FETTE

1 kg.



FLA173935
EDAMER FETTE

140 gr.



FLA173942
EDAMER FETTE S/LATTOSIO

100 gr.



FLA181245
CHEDDAR S/LATTOSIO

100 gr.



FLA181235
EMMENTAL FETTE

140 gr.



FLA181242
EMMENTAL S/LATTOSIO

100 gr.



FLA180000
EMMENTAL BAVARESE

250 gr.



FLA118045
CACIOTTA S/LATTOSIO
100 gr.



FLA118035
CACIOTTA FETTE
140 gr.



FLA182142
TILSITER S/LATTOSIO
100 gr.



FLA173035
MOZZARELLA FETTE
140 gr.



FLA173024
PASTA FILATA AFFUMICATA
140 gr.



FLA236000
FETTE
200 gr.



FLA840002
PAMIGO CANESTRATO
1 kg. circa



FLA820002
PAMIGO TELONATO
1 kg. circa



FLA074300
FORMAGGIO PASTI STRAVECCHIO
5 kg. circa



FLA65510
ALPIGIANA FORM. FRESCO
150 gr.



FLA155500
FIOTTO
150 gr.



85425
EDAMER ALPENSILBER 40%
3 kg. circa



FLA116604
MOZZARELLA S/LATTOSIO
100 gr.



FLA118006
CACIOTTINA S/LATTOSIO
220 gr.



FLA116821
MOZZARELLA CILIEGINA
125 gr.



FLA309100
PANNA X CAFFÈ
10x10 gr.



FRESCHI



Tomini FORMAGGI



FL17A
TOMINO ERBE SOTT'OLIO
150 gr.



FLD48L
TOMINO DEL BOSCAIOLO
2 pz.



FL048O
TOMINO DEL BOSCAIOLO
1 kg.



FLV21
TOMINO VASO VERDE
2,1 kg.



FLR21
TOMINO VASO ELETRIC
2,1 kg.



FL07D
CREMA DEL BOSCAIOLO
200 gr. | SPALMABILE



FL20Q
TOMA OLIO PEPERONCINO
250 gr.



FL20QV
TOMA OLIO ERBE (VERDE)
250 gr.



FL05M
TOMA PIEMONTESE DOP
200 gr.

FRESCHI



LE ECCELLENZE

La nostra è sempre stata una famiglia di stagionatori, e, per noi, sono importanti le memorie in comune che condividiamo, ma soprattutto il rispetto del valore delle competenze maturate nel corso delle generazioni.

“Quando negli anni Settanta la maggior parte degli allevatori si è trasferita in pianura, il papà ha continuato a ritirare i formaggi in Val Taleggio e a stagionare nelle nostre piccole cantine di casa, ha affinato un metodo, lavorando su produzioni locali di qualità.

Da lui abbiamo imparato questo lavoro, basandoci sulle sue competenze e cercando di migliorarci sempre. Siamo fortemente convinti che insieme possiamo fare qualcosa di importante per noi e per la Val Taleggio.”





FLAB86010
BRANZI
 7 kg. circa



FLAB86020
BRANZI LATTE CRUDO
 1/4 - 800 gr. circa



FLAF77000
FORMAGGELLA " G " NOSTRANA
 2,5 kg. circa



FLAS75032
STRACCHINO VEDESETA
 1,6 kg. circa



FLRS75030
STRACHITUNT VALTALEGGIO
 5 kg. circa



FLRS75033
STRACHITUNT DOP
 1/4 - 1,5 kg. circa



FLRO76011
ROCOLO FORM. VALTALEGGIO
 2,5 kg. circa



FLRR99119
ROSSO IMPERIALE
 2,1 kg. circa



FLRO76020
ROCOLO DIVINO
 2,5 kg. circa



FLRO76098
**ROCOLINO
 AL TARTUFO**
 300 gr. circa



FLQS76033
**ROCOLINO
 DEL MEDITERR.**
 300 gr. circa



FLDZ76075
**ROCOLINO
 NERO IMPERIALE**
 300 gr. circa



FLRO76090
**ROCOLINO
 VALTALEGGIO**
 300 gr. circa



FLAF77021
ALBEN VALTALEGGIO
1/4 - 1,4 kg. circa



FLAF77015
ALBEN VALTALEGGIO
5,5 kg. circa



FLDV99054
BITTO VALT. DOP
1/4 2,5 Kg



FLDF89016
FONTINA DOP AOSTA
1/4 - 2,5 kg. circa



FLDH99036
CASTELMAGNO DOP
1/4 700 gr. circa



FLDH99032
CASTELMAGNO DOP FORMA
2,5 kg. circa



FLDF89010
FONTINA VERA AOSTA
10 kg. circa



FLAR80020
FORM. PIZZINO
500 gr. circa



FLAD84010
FORMAGI' STAGIONATO
680 gr. circa



FLAF16040
TARTU' - PREGIATO AL TARTUFO
1,1 kg. circa



FLTC70350
TALEGGIO DOP LATTE CRUDO
forma 2 kg. circa



FLTA10040
TALEGGIO DOP VERO ARR.
1,5 kg. circa



FLTF10701
TALEGGIO DOP VERO
200 gr.



FLDC96033
VALT. CASERA DOP
1/4 . 2 kg. circa



FLDC96030
VALT. CASERA DOP
FORMA 8,5 kg. circa



FLCA19043
BLU DI CAPRA
1,5 kg. circa



FLCA19013
NABABBO - STAG. DI CAPRA
1,1 kg. circa



FLCA19020
CACIOTTA DI CAPRA
400 gr. circa



FLGP87041
GORGONZOLA DOP PICCANTE
1/8 - 1,5 kg. circa



FLGD87019
GORGONZOLA DOP AL CUCC.
1/4 - 3 kg. circa



FLGD87050
GORGONZOLA DOP AL CUCC.
1/2 | 6 kg. circa



FLGD 87015
GORGONZOLA DOP DOLCE
1/8 - 1,5 kg. circa



FLGD87035
GORGONZOLA DOP DOLCE
200 gr.



FLDZ76028
NERO IMPERIALE "S.PIETRINO"
1,5 kg. circa



FLRL87083
BELZEBLU PICCANTE
1/8 1,5 kg. circa



FLRT50010
TORTA LA BRUNA
4,5 kg. circa



FLQT71010
QUARTIROLO L. DOP BERGAMINO
1,1 kg. circa



FLQB20010
QUARTIROLO LOMB. DOP FRES.
2,5 Kg



FLQB20025
QUARTIROLO LOMB. DOP FRES.
1/2 - 1,1 kg circa



FLQN20706
QUARTIROLO LOMB. DOP FRES.
200 gr.

FRESCHI

BEPPINO OCCELLI®

i sapori dell'eccellenza

Fornaggi AFFINATI E RARITÀ

Quella di Beppino Occelli è una personalissima storia del gusto ricca di intuizioni, progetti e soddisfazioni, ma anche di sacrifici ed incomprensioni a causa di una mentalità e di uno stile di vita imposto dalla logica industriale e dall'impovertimento culturale della campagna e della montagna. Contro questa tendenza all'omologazione, Beppino Occelli ha proposto creazioni e interpretazioni personali dei prodotti della tradizione che nascono dal suo profondo e indissolubile amore per il territorio dove è nato: le Langhe e le Alpi.





FLBOS33FR
AL Fieno MAGGENGO

1/4 - 1,3 kg. circa



FLBOS31AR
AL PEPE NERO E BACCHE ROSA

1/4 - 1,3 kg. circa



FLBOS68AQ
AL MALTO D'ORZO E WHISKY

1/4 - 1,3 kg. circa



FLBOS44AQ
AL BAROLO

1/4 - 1,3 kg. circa



FLBOS17AQ
FRUTTA E GRAPPA DI MOSCATO

1/4 - 1,3 kg. circa



FLBOS25AQ
IN FOGLIE DI CASTAGNO

1/4 - 1,3 kg. circa



FLBOS39AQ
IN FOGLIE DI TABACCO E RHUM

1/4 - 1,3 kg. circa



FLBOS33AR
CASTELMAGNO D'ALP. DOP

1/2 - 2,5 kg. circa



FLBO0005
CRUTIN

300 gr. circa



FLBOS43AC
VALCASOTTO

6 kg. circa



FLBOS43AR
VALCASOTTO 24 MESI

1/2 - 3 kg. circa



FLBOS60AQ
BIANCO DI LANGA AL TARTUFO

1/4 - 1,5 kg. circa



FLBOS73AR
CUSIÈ PECORA E VACCA

1/2 - 3 kg. circa



FLBOS74AR
CUSIÈ CAPRA E VACCA

1/2 - 3 kg. circa



FLBOS74AQ
CUSIÈ CAPRA E VACCA - 24 MESI

1/4 - 1,5 kg. circa



FLBO0004
BLOCCO DI BURRO

3 kg. circa



FLBO1UA / FLBO1TA
BURRO STELLA ALPINA

200 gr. / 100 gr



FLBOB80QG
BURRO AL TARTUFO D'ESTATE

80 gr.



FLBOC28FA
TUMA D'LA PAJA

250 gr. circa



FLBOC20FA
TUMA DE FEJA 100% PECORA

250 gr. circa



FLBOC33FA
CRAVA 'ANTAN 100% CAPRA

250 gr. circa



FLBOC09FF
CASUTIN

100 gr. circa



FLBOC27FA
TUMA DEL TRIFULAU

250 gr. circa



FLBOS09AC
TOMA DEL MONTE REGALE

7 kg. circa



FLBOS03AC
LOSA DI VACCA

2,5 kg. circa



FLBOS49AC
LOSA CON CAPRA

2,5 kg. circa



FLBOS65AC
VERZIN 100% VACCA

2,5 kg. circa



FLBOC08FA
ROBIOLA

250 gr. circa



FLBOC23FA
MINI ROBIOLA

130 gr. circa



FLBOS63AC
VERZIN 100% CAPRA

2,5 kg. circa



FRESCHI



FORMAGGI

Del Territorio



FLCPBOMB
BOMBOLONE MONTE PORA

700 gr. circa



FLCPFORVS
FORMAGGELLA VALSERIANA

1,8 kg. circa



FLCPRUSTI
FORMAI DE RUSTI'

2,5 kg. circa



FLCLP LATTO
LATTERIA VALLE SERIANA

1/4 - 1,5kg. circa



FLCP000224
RUSTICHELLO

1,5 kg. circa



FLCPTAV
TOMA ALTA VALLE

3,5 kg. circa



FLCPSTRAGRO
STRACCHINO DI GROMO

1,9 kg. circa



FLCP000222
TORRE DI GROMO

500 gr. circa



FRESCHI



Formaggi TUTTI I GRANDI CLASSICI

Il Caseificio Defendi i suoi formaggi li fa così, buoni e basta, senza altro da aggiungere. Bisogna assaggiarli per capire cosa significano più di 150 anni di esperienza, dove il lavoro del casaro è diventato maestria, un'arte da insegnare e tramandare. Tutti i formaggi Defendi, dal Gorgonzola DOP al Taleggio DOP, sono un'armonia di sapori, l'inevitabile risultato che deriva dalla saggezza di chi sa di avere una tradizione da custodire e al tempo stesso la voglia di sperimentare e innovare.





FLDE4646
ASIAGO PRESSATO

1/4 - 1,5 kg. circa



FLDE4600A
EMMENTHAL

1/2 45 kg. circa



FLDE4600
EMMENTHAL INTERO

90 kg. circa



FLDE4113
FONTAL

1/4 - 1,5 kg. circa



FLDE1324
ITALICO

1 kg. circa



FLDE4616
FORM. OLANDESE

1/4 - 1,7 kg. circa



FLDE4501
GRANA PADANO - 36 MESI

1/4 - 8 kg. circa



FLDE4532
GRANA PADANO GRATT.

100 gr.



FLDE2060
MASCARPONE

500 gr.



FLDE2960
BURRO

250 gr.



FLDE1561
CRESCENZA B/LATTE

250 gr. circa



FLDE1556
CRESCENZA C/LATTE

Kg.1



FLDE5212
BUFALETTO CON L. DI BUFALA

2 kg. circa



FLDE1800A
BAFFALO BLU

1/2 - 2 kg. circa



FLDE1800B
BAFFALO BLU

1/4 - 1 kg. circa



FLDE5900
CAMEMBERT DI BUFALA

300 gr. circa



FLDE5452
CAPRA STAGIONATA

3 kg. circa



FLDE4201
BRIE

Kg.1



FLDE1813
GORGONZOLA PICCANTE

1/8 - 1,5 kg. circa



FLDE1912
GORGONZOLA DOP EXTRA 1/4

3 kg. circa



FLDE1913
GORGONZOLA DOP EXTRA 1/8

1,5 kg. circa



FLDE1851
GORGONZOLA, MASC. E NOCI

1,2 kg. circa



FLDE4902
SOTTILETTE KRAFT

200 gr.



FLDE5500
PHILADELPHIA

2x80 gr.



FLDE4710
PECORINO BRIGANTE

3 kg. circa



FLDE4725
PECORINO FIORE PASTORE

2 kg. circa



FLDE4723
PECORINO MOLITERNO

4 kg. circa



FLDE1502
PRIMOSALE

1 kg. circa



FLDE4772 / FLDE4772A
PROV. DOLCE AURICCHIO

6 kg. circa / 1/2 3 kg. circa



FLDE4773
PROV. PICCANTE

6 kg. circa / 1/2 3 kg. circa



FLDE1210
QUARTIROLO FRESCO

1/2 - 1 kg. circa



FLDE1230
QUARTIROLO STAGIONATO

2 kg. circa



FLDE4672
ROSA CAMUNA

1,5 kg. circa



FLDE1010
TALEGGIO BASSO

1,2 kg. circa



FLDE1003
TALEGGIO CARAVAGGIO

2 kg. circa



FLDE1017
TALEGGIO CARAVAGGIO

1/2 - 1 kg. circa



FLDE1100
TALEGGIO DOP S. ANTONIO

2 kg. circa



FLDE5198
MOZZARELLA DI BUFALA

125 gr.



FLDE1320
TORTA PRIMAV. DI CARAVAGGIO

600 gr. circa



FLDE1420
ROSABIANCA

400 gr. circa



FLDE1301
SALVA

2 kg. circa



FLDE1301A
SALVA

1/2 - 1 kg. circa

FRESCHI

*Quelli buoni !*

Di Capra

FORMAGGI



FLCAB
CABRETT

180 gr.



FLCP5
CAPRALPINA

5 kg. circa



FLCPN
CAPRINOTTA

2 kg. circa



FLSC
SADICAPRA "PASTA CRUDA"

2 kg. circa



FLCU
CRU DI CAPRA

3,5 kg. circa



FLDC1
DOLCECREMA CAPRA VASO

150 gr.



FLDVC2
DELIZIOLA ERB.CAPRA

1/2 - 6 kg. circa



FLDVC3
DELIZIOLA ERB.CAPRA

1/8 - 1,5 kg. circa



FLFCP2
FIORDICAPRA TOMINO

150 gr.



FLSCS
STRACCO DI CAPRA

2,2 kg. circa



FLRCA
ROCCAPRINA

400 gr.



FLGRC
GROTI' TOMINO CAPRA

700 gr. (8 pz.)v



FLGC8
GRANCAPRA

1/8 - 2,5 kg. circa



FLMCN
MONTECAPRA NERO

2 kg. circa



FLMCP
MONTECAPRA STAGION.

2,4 kg. circa



FLFB2
FETA GRECA

200 gr.



FLFT1
FETA GRECA DOP

2 kg. circa



FLYG1
CREMA YOGURT GRECO TYRAS

1 kg.

FRESCHI



Di Pecora FORMAGGI



FLNOCP
PECORINO CON NOCI

1 kg. circa



FLCHIP
PECORINO CON PEPE NERO

1 kg. circa



FLPPRP
PECORINO CON PEPERONCINO

1 kg. circa



FLPESP
PECORINO CON PESTO

1 kg. circa



FLPVPI
PECORINO DELLA VAL D'ORCIA

2,5 kg. circa | STAGIONATO



FLDOPT
PECORINO TOSCANO

2 kg. circa | PASTA TENERA



FRESCHI

TENUTA
Agrisat

Di Bufala
MOZZARELLA



FL100B
BOCCONCINI BUFALA
250 gr.



FL100M
MOZZARELLA BUFALA
250 gr.



FL100T
TRECCIONE BUFALA
2 kg.



FL100TB
TRECCIONE BUFALA
1 kg.



FL100RS
RICOTTA SALATA
300 gr.

FRESCHI

Artigiana®
CASEIFICIO
Passione e bontà tutti i giorni

Formaggi Filati

FORMAGGI



FL00820
STRACCIATELLA AFFUMICATA

250 gr. | BICCHIERE



FL00809
STRACCIATELLA

250 gr. | BICCHIERE



FL00801
STRACCIATELLA

1 kg.



FL00132
FIOR DI MASSERIA

200 gr.



FL00610
BURRATA CIUFFO

6x125 gr. (750 gr.)



FL00688
BURRATA AFFUMICATA

125 gr. | BICCHIERE



FL00605
BURRATA

125 gr. | BICCHIERE



FL00501
BURRATA

1 kg. | VASCHETTA



FL00508
BURRATA SINGOLA

300 gr.



FL01303
TRECCIA AFFUMICATA

1 kg. circa



FL02302
CAPASONE

5 kg. circa



FL01306
SCHIACCIATINA AFFUMICATA

1 kg. | VASCHETTA



FL02309
CACIOCAVALLO IN GROTTA

1,2 kg. circa



FL08001
CACIOCAVALLO IN VINACCIA

1,2 kg. circa



FL02314
CACIOCAVALLO STRAVECCHIO

1,2 kg. circa in box



FL03760
BIANCO FIOCCO

500 gr. circa



FL01523
GIUNCO BIANCO

1,5 kg.



FL01524
GIUNCO RUCOLA

1,5 kg.



FL00202
NODINO

1 kg. vaschetta



FL00250
NODINO

250 gr. vaschetta



FL03756
RICOTTA DI CAPRA

200 gr.



FL01803
RICOTTA FRESCA

300 gr.



FL01801
RICOTTA FRESCA

1,5 kg.



FL01802
RICOTTA CON LATTE DI PECORA

500 gr.



FL01301
SCAMORZA AFFUMICATA

1 kg.



FL001101
SCAMORZA BIANCA

1 kg.



FL00156
CILIEGINA DI MOZZARELLA

250 gr.

FRESCHI



LATTICINI e Formaggi

LATTICINI



FL0040
GRANA PADANO FORMA

32 kg. circa



FL1547
GRANA PAD. TRANCI

1/4 - 8 kg. circa



FL3965
GRANA PADANO MONODOSE

200x5 gr.



FL3904
PADANO GRATT.

100 gr.



85774
GRANA PADANO GRATT.

1000 gr.



FL1567
GRANA PADANO TRANCI

1/8 - 4 kg. circa



FL2601
PAR. REGGIANO TRANCI

1/8 - 4 kg. circa



FL3532
PARMIG. REGGIANO GRATT.

80 gr.



FL0201
PROV. DOLCE ANONIM.
5 kg.



FL0366
PROV. PICC. ANONIM.
11 kg.



FL0202
PROV. PICC. ANONIM.
6 kg.



FL3305
PROV. PICC. ATM
250 gr.



FL3119
PROV. DOLCE ATM
250 gr.



FL0259
CACIOCAVALLO
1,9 kg. circa



FL3537
LATTE INTERO SQUARE
1 l.



FL3542
LATTE INTERO UHT
500 l.



FL3543
LATTE P.S. UHT
500 l.



FL3538
LATTE P.S. SQUARE
1 l.



FL3741
LATTE SCREMATO
500 l.



FL3553
LATTE UHT ALTA DIGERIBILITÀ
1 l.



FL3815
BURRO SORES. GOURMET
1 kg.



FL3618
BURRO PANI SORESINA
125 gr.



FL3614
BURRO PANI SORESINA
250 gr.



FL3638
BURRO SCATOLA
250 gr.



FL3625
BURRO SENZA LATTOSIO
125 gr.



FL3626
BURRO SENZA LATTOSIO
250 gr.

FRESCHI



Pastifici PASTIFICI

“Pastificio Orobico” e “La Marchesina” sono produttori locali che si dilettono nell’interpretare le antiche ricette del territorio Lombardo lavorando attraverso moderne tecnologie e materie prime di alta qualità.





FL1101
CASONSEI DELLA BERGAMASCA
250 gr. • 1 kg.



FL1110
SCARPINOCC DE PAR
250 gr. • 1 kg.



FL1140
CASONCELLI VALTELLINESI
250 gr.



FL1170
PANSOTTI SPECK TREVISANA
250 gr.



FL1470
RAVIOLI FORMAI DE MUT
250 gr.



FL1160
TRIANGOLI FUNGHI PORCINI
250 gr.



FL1260
CASONCELLI CARNE
250 gr.



FL1270
CASONCELLI CRUDO
250 gr.



FL1230
QUADRUCCI CARNE
250 gr.



FL1290
CAPPELLETTI AL CRUDO
250 gr.



FL1320
TORTELLI RICOTTA SPINACI
250 gr.



FL2146
TROFIE FRESCHE
250 gr.



FL2148
ORECCHIETTE FRESCHE
250 gr.



FL2100
TAGLIATELLE ALL'UOVO
250 gr.



FL2130
PIZZOCCHERI VALTELLINESI
250 gr.



FL4102
GNOCCHI
500 gr.



FL4120
GNOCCHI MIGNON
500 gr.





82103
CASONCELLI 1A SCELTA

1 kg.



82050
CASONCELLI ECO

1 kg.



82101
SCARPINOCC

1 kg.



82104
RAVIOLI VALTELLINA

1 kg.



82115
STROZZAPRETI

1 kg.



82052
RAVIOLI AL BRASATO ECO

1 kg.



82053
TORTELLINI AL CRUDO ECO

1 kg.



82054
RAVIOLI BANCHI/VERDI ECO

1 kg.



82051
RAVIOLI RICOTTA SPINACI ECO

1 kg.



82124
CAPPELLETTI PICCOLI

1 kg.



82125
MIGNON CARNE

1 kg.



82055
RAVIOLI AL BRASATO STACCATI

1 kg.



82120
TAGLIATELLE ALL'UOVO

1 kg.



82121
TAGLIOLINI ALL'UOVO

1 kg.



82126
TAGLIOLINI CASTAGNA

1 kg.



82102
RAVIOLI ERBA CIPOLLINA

1 kg.



82109
RAVIOLI ALLA ZUCCA

1 kg.



82110
RAVIOLI AI FUNGHI

1 kg.



82111
RAVIOLI AL BRANZINO

1 kg.



82112
RAVIOLI ALL'ASTICE

1 kg.



82105
RAVIOLI AI CARCIOFI

1 kg.



82106
RAVIOLI AL SALMONE

1 kg.



82128
RAVIOLI AL NERO DI SEPPIA

1 kg.



82100
CASONESI DELLA BERGAMASCA

1 kg.



82127
TAGLIOLINI NERO DI SEPPIA

1 kg.



82108
TROFIE

1 kg.



82122
ORECCHIETTE

1 kg.



SU ORDINAZIONE
RAVIOLI SPECK E RADICCHIO

1 Kg.



SU ORDINAZIONE
CARAMELLE RICOTTA E SPINACI

1 Kg.



SU ORDINAZIONE
CREPPELLE PROSC. E FORMAGGIO

1 Kg.



SU ORDINAZIONE
RAVIOLI AL VITELLO

1 Kg.



SU ORDINAZIONE
FAGOTTINO AL PARMIGIANO

1 Kg.



SU ORDINAZIONE
RAVIOLI ALLA FONDUTA

1 Kg.



SU ORDINAZIONE
RAVIOLI RADICCHIO E SCAMORZA

1 Kg.



SU ORDINAZIONE
RAVIOLI AGLI ASPARAGI

1 Kg.



SU ORDINAZIONE
RAVIOLI ALLA RUCOLA

1 Kg.



SU ORDINAZIONE
FIOCCHETTI TALEGGIO E RUCOLA

1 Kg.



SU ORDINAZIONE
RAVIOLI AL LIMONE

1 Kg.



SU ORDINAZIONE
RAVIOLI AL TARTUFO

1 Kg.



SU ORDINAZIONE
RAVIOLI ALLA SELVAGGINA

1 Kg.



SU ORDINAZIONE
AGNOLOTTI AL BRASATO

1 Kg.



SU ORDINAZIONE
FAGOTTINO ARROSTO DI MANZO

1 Kg.



SU ORDINAZIONE
QUADRETTO RICOTTA E SPINACI

1 Kg.



SU ORDINAZIONE
RAVIOLI ALLE NOCI

1 Kg.



SU ORDINAZIONE
CARAMELLE ALLA BRESAOLA

1 Kg.



SU ORDINAZIONE
FIOCCHETTI SCAMORZA CRUDO

1 Kg.



SU ORDINAZIONE
CREPELLONE MOZZ. DI BUFALA

1 Kg.



SU ORDINAZIONE
RAVIOLONI AL PETTO D'OCA

1 Kg.



FRESCHI

La Marchesina
PASTIFICIO
di casa tua

Torte da Forno



82000
NOCI E FICHI

Torta da forno



82002
MELE

Torta da forno



82003
ALBICOCHE

Torta da forno



82004
MIRTILLI

Torta da forno



82005
FRUTTI DI BOSCO

Torta da forno



82007
LIMONE

Torta da forno



82008
CIOCCOLATO

Torta da forno



82006
PERE E CIOCCOLATO

Torta da forno



82001
NONNA

Torta da forno

FRESCHI



Pasta Fresca PASTA FRESCA

Se si parla di pasta fresca non si può non pensare subito alla lunga tradizione culinaria italiana. Per gli italiani, la parola "pasta" significa casa, famiglia e tradizione. "Giovanni Rana" è marchio leader nel settore e uno dei simboli dell'italianità nel mondo.





FL11159
SF.VELO MONO PROSC. CRUDO
125 gr.



FL11160
SF.VELO MONO RIC. SPINACI
125 gr.



FL11201
SF.VELO MONO CARNE
125 gr.



FL11121
SF.VELO MONO VITELLO
125 gr.



FL11042
SOGLIAVELO CARNE
250 gr.



FL11102
SOGLIAVELO BRASATO
250 gr.



FL11741
RUSTICI CAPPELLETTI CRUDO
250 gr.



FL11740
RUSTICI TORTELLINI CARNE
250 gr.



FL11745
RUSTICI TORTELLINI CASERECCI
250 gr.



FL11744
RUSTICI RAVIOLINI VITELLO
250 gr.



FL14190
G. VERDE CARCIOFI
250 gr.



FL14193
G. VERDE RADICCHIO
250 gr.



FL14191
G. VERDE ZUCCA
250 gr.



FL14192
G. VERDE FUNGHI PORCINI
250 gr.



FL16591
SFOGLIAGREZZA TAGLIATELLE
250 gr.



FL15023
N. TRADE GNOCCHI
500 gr.



FL15011
GNOCCHETTI DI PATATE
500 gr.



FL16451
TROFIETTE
500 gr.



FL16450
ORECCHIETTE
500 gr.



FL11315
N. TRADE TORTELLINI CARNE
250 gr.



FL11317
N. TRADE TORT. RIC. SPINACI
250 gr.



FL11318
N. TRADE RAVIOLI FUNGHI
250 gr.



FL11316
N. TRADE CAPPELLETTI CRUDO
250 gr.



FL16536
N. TRADE LASAGNE FRESCHE
250 gr.



FL16526
SFOGLIAVELO LASAGNE
250 gr.



FL15141
SPADELLINI POM. MOZZARELLA
280 gr.



FL15140
SPADELLINI FORMAGGI
280 gr.



FL15142
SPADELLINI PROS. MOZZARELLA
280 gr.



FL15143
SPADELLINI SPIN. MOZZARELLA
280 gr.



FL61200 • FL61201
LASAGNE ALLA BOLOGNESE
350 gr. • 900 gr.



FL61205
LASAGNE RICOTTA SPINACI
350 gr.



FL18163
SUGO FRESCO PARMIGIANO
150 gr.



FL18185
SUGO FRESCO BOLOGNESE
225 gr.



FL18186
SUGO FRESCO AMATRICIANA
225 gr.



FL18162
SUGO FRESCO FUNGHI
180 gr.



FL18140
PESTO FRESCO SENZ'AGLIO
140 gr.



FL18141
PESTO FRESCO GENOVESE
140 gr.



FRESCHI

TUSCANY
MAGRINI
DAL 1978

Pesto e Salse PESTO E SALSE

Nel cuore di Massa, sorge un punto di riferimento per gli amanti della gastronomia: Magrini Le Delizie, produttori di salse in Italia con una storia che abbraccia oltre 40 anni di passione e dedizione. La nostra azienda è stata fondata nel 1978 da Cesare Magrini, un uomo ispirato dalla sua connessione con la cucina ligure, in particolare con il celebre pesto alla genovese.

Nel corso degli anni ci siamo evoluti, mantenendo al contempo salda l'artigianalità e la qualità dei nostri prodotti.



FLPE21
PESTO GENOVESE

2100 gr.



FLPE80
PESTO GENOVESE

80 gr.



FLSV12
SALSA VERDE

1200 gr.

RETAIL E CATERING



Gastronomia Fresca
GASTRONOMIA FRESCA





PP0005
**MELANZANE
ALLA PARMIGIANA**

1500 g. | frigorifero 0°C / +4°C.



PP0011
**LASAGNE
ALLA BOLOGNESE**

1500 g. | frigorifero 0°C / +4°C.



PP0030
**MINISTRA DI PANE
RIBOLLITA**

2500 g. | frigorifero 0°C / +4°C.



P0046
PAELLA ALLA VALENCIANA

2000 g. | frigorifero 0°C / +4°C.



PP0100
TRIPPA ALLA FIORENTINA

2000 g. | frigorifero 0°C / +4°C.



PP0300
MERLUZZO ALLA LIVORNESE

2000 g. | frigorifero 0°C / +4°C.



PP0600
SEPIE IN ZIMINO

2000 g. | frigorifero 0°C / +4°C.



PP0660
FAGIOLINI E MAZZANCOLLE

2500 g. | frigorifero 0°C / +4°C.



PP1630
INSALATA RUSSA

1000 g. | frigorifero 0°C / +4°C.



PP1660
COUS COUS VEGETARIANO

1500 g. | frigorifero 0°C / +4°C.



PP0322
INSALATA DI RISO FREDDA

2000 g. | frigorifero 0°C / +4°C.



PP0370
INSALATA DI FARRO FREDDA

2000 g. | frigorifero 0°C / +4°C.



82746
CANNELLONI CARNE
300 g. | 0°C / +4°C.



82687
LASAGNE BOLOGNESE
400 g. | 0°C / +4°C.



82777
CREPELLE AI FUNGHI
300 g. | 0°C / +4°C.



82685
CANNELLONI RICOTTA SPINACI
300 g. | 0°C / +4°C.



82708
LASAGNE RADICCHIO E PROVOLA
400 g. | 0°C / +4°C.



82686
CREPELLE PROSCIUTTO FORM.
300 g. | 0°C / +4°C.



82722
FETTUCINE CARBONARA
250 g. | 0°C / +4°C.



82721
FETTUCINE AL SALMONE
250 g. | 0°C / +4°C.



82735
FETTUCINE ALLA BOSCAIOLA
250 g. | 0°C / +4°C.



82765
MELANZANE ALLA PARMIGIANA
300 g. | 0°C / +4°C.



82738
TORTELLINI ALLA BOLOGNESE
250 g. | 0°C / +4°C.



82690
TORTELLINI PANNA PROSCIUTTO
300 g. | 0°C / +4°C.



82315
BROCCOLI AL VAPORE
200 g. | 0°C / +4°C.



82312
CAROTINE BABY AL VAPORE
280 g. | 0°C / +4°C.



82317
FAGIOLINI FINISSIMI AL VAPORE
250 g. | 0°C / +4°C.



82716
SPINACI AL VAPORE
280 g. | 0°C / +4°C.



82717
TRIS DI VERDURE AL VAPORE
280 g. | 0°C / +4°C.



82320
ZUCCHINE A CUBETTI AL FORNO
250 g. | 0°C / +4°C.



82680
ARROSTO DI TACCHINO C/PATATE
250 g. | 0°C / +4°C.



82727
BACCALÀ CON POLENTA
300 g. | 0°C / +4°C.



82681
BRASATO ALLE VERDURE
250 g. | 0°C / +4°C.



82729
INVOLTINI DI POLLO C/PATATE
280 g. | 0°C / +4°C.



82683
SCALOPPINE AL VINO BIANCO
220 g. | 0°C / +4°C.



82730
POLPETTE DI CARNI BIANCHE POM.
280 g. | 0°C / +4°C.



82725
SCALOPPINE AGLI ASPARAGI
250 g. | 0°C / +4°C.



82736
SCALOPPINE ALLA PIZZAIOLA
220 g. | 0°C / +4°C.



82677
SCALOPPINE PANNA E FUNGHI
220 g. | 0°C / +4°C.



82682
SCALOPPINE RADICCHIO E PROV.
220 g. | 0°C / +4°C.



82316
PATATE AL FORNO
300 g. | 0°C / +4°C.



82321
MELANZANE GRIGLIATE
220 g. | 0°C / +4°C.



82689
SEPPIE CON PISELLI
220 g. | 0°C / +4°C.



82313
PATATE RUSTICHE A SPICCHI
280 g. | 0°C / +4°C.



82322
PEPERONI GRIGLIATI
220 g. | 0°C / +4°C.



82737
SPEZZATINO CON PATATE
220 g. | 0°C / +4°C.



82726
STRACOTTO DI CAVALLO
350 g. | 0°C / +4°C.



82684
TAGLIATA DI POLLO AI CARCIOFI
220 g. | 0°C / +4°C.



82745
TRIPPA ALLA PARMIGIANA
350 g. | 0°C / +4°C.



82768
VITELLO TONNATO
220 g. | 0°C / +4°C.



82781
INSALATA DI POLLO C/VERDURE
250 g. | 0°C / +4°C.



82782
SCALOPPINE LIMONE C/VERDURE
300 g. | 0°C / +4°C.



82792
SPIEDONI GRATI DI SURIMI
320 g. | 0°C / +4°C.



82790
RISO ROSSO, VERDURE E POLLO
250 g. | 0°C / +4°C.



82780
INSALATA DI RISO VEG.
250 g. | 0°C / +4°C.



82791
POLLO AL CURRY E BASMATI
250 g. | 0°C / +4°C.



82772
ARROSTO DI MAIALE
1500 g. | 0°C / +4°C.



82679
ARROSTO DI TACCHINO
1500 g. | 0°C / +4°C.



82705
ARROSTO DI VITELLO
1500 g. | 0°C / +4°C.



82742
BRASATO ALLE VERDURE
1500 g. | 0°C / +4°C.



82762
COTOLETTA DI PETTO DI POLLO
1500 g. | 0°C / +4°C.



82739
INVOLTINI DI POLLO
1500 g. | 0°C / +4°C.



82710
OLIVE ALL'ASCOLANA

1500 g. | 0°C / +4°C.



82758
PETTO DI POLLO AI PEPERONI

1500 g. | 0°C / +4°C.



82753
PETTO DI POLLO GRIGLIATO

1500 g. | 0°C / +4°C.



82774
POLPETTE DI CARNI BIANCHE

1500 g. | 0°C / +4°C.



82770
SCALOPPINE AI FUNGHI

1500 g. | 0°C / +4°C.



82752
SPEZZATINO CON PATATE

250 g. | 0°C / +4°C.



82775
STRACOTTO EQUINO

2000 g. | 0°C / +4°C.



82773
TAGLIATA DI POLO AI CARCIOFI

1500 g. | 0°C / +4°C.



82700
VITELLO TONNATO

1200 g. | 0°C / +4°C.



82734
BACCALÀ ALLA VICENTINA

1500 g. | 0°C / +4°C.



82701
CAPESANTE GRATINATE

1000 g. | 0°C / +4°C.



82698
FILETTO DI TROTA SALMONATA

1000 g. | 0°C / +4°C.



82663
GAMBERI IN SALSA ROSA

1000 g. | 0°C / +4°C.



82751
INSALATA DI MARE EXTRA

1000 g. | 0°C / +4°C.



82665
INSALATA DI POLPO A RONDELLE

1000 g. | 0°C / +4°C.



82709
LUCCIO IN SALSA
1500 g. | 0°C / +4°C.



82667
MERLUZZO FRITTO PASTELLATO
1200 g. | 0°C / +4°C.



82711
MERLUZZO IMPANATO
1500 g. | 0°C / +4°C.



82744
SEPIE CON PISELLI
1500 g. | 0°C / +4°C.



82129
SPIEDONI SURIMI GRATI
1500 g. | 0°C / +4°C.



82750
PAELLA ALLA VALENCIANA
1500 g. | 0°C / +4°C.



82756
CANNELLONI ALLA CARNE
2000 g. | 0°C / +4°C.



82741
CRESPELLE PROSC. FORMAGGIO
1500 g. | 0°C / +4°C.



82748
LASAGNE VITELLO E ASIAGO
2500 g. | 0°C / +4°C.



82778
LASAGNE AL FORNO
1000 g. g. | 0°C / +4°C.



82766
LASAGNE ALL'EMILIANA
2500 g. | 0°C / +4°C.



82785
INSALATA DI FARRO CON TACC.
1500 g. | 0°C / +4°C.



82767
INSALATA CONTADINA

1000 g. | 0°C / +4°C.



82764
INSALATA DI POLLO

1500 g. | 0°C / +4°C.



82692
INSALATA DI RISO

1500 g. | 0°C / +4°C.



82784
COUS COUS CON POLLO E VERD.

1500 g. | 0°C / +4°C.



82732
MELANZANE ALLA PARMIGIANA

1500 g. | 0°C / +4°C.



82733
NERVETTI FANTASIA

500 g. | 0°C / +4°C.



82771
CIPOLLINE AL FORNO

1000 g. | 0°C / +4°C.



82706
PATATE TONDE AL FORNO

2000 g. | 0°C / +4°C.



82720
PEPERONI RIPIENI

1500 g. | 0°C / +4°C.



82719
POMODORI GRATINATI

1000 g. | 0°C / +4°C.



82755
SPINACI AL VAPORE

1000 g. | 0°C / +4°C.



82731
INSALATA RUSSA

1000 g. | 0°C / +4°C.

FRESCHI



YOGURT

La Latteria Vipiteno è una delle aziende più antiche e ricche di tradizione dell'Alto Adige. Il settore principale in cui siamo attivi e nel quale riscuotiamo grande successo è la produzione e commercializzazione dello yogurt. Per arrivare a questi risultati abbiamo percorso un lungo cammino, non sempre facile. Vipiteno e dintorni infatti, così come la parte settentrionale della nostra regione, è noto per il vento freddo e sferzante. Non era quindi possibile coltivare frutta e verdura come nella parte meridionale della regione. Per questo, i nostri contadini dovettero trovare una soluzione alternativa per poter sopravvivere, dedicandosi all'allevamento di animali da latte. Fu così che iniziarono a utilizzare il latte prodotto per il consumo familiare.





FL10250
INTERO
2x125 gr.



FL10217
VANIGLIA
2x125 gr.



FL27221
**SAP. MELISSA
E MIELE**
2x125 gr.



FL10251
MAGRO
2x125 gr.



FL10213
NOCCIOLA
2x125 gr.



FL27226
**SAPORI MIRTILLO
ROSSO**
2x125 gr.



FL10227
MANGO
2x125 gr.



FL10212
MIRTILLO
2x125 gr.



FL27233
**SAPORI MORA
MELOGRANO**
2x125 gr.



FL10220
**PERA
E CAMOMILLA**
2x125 gr.



FL10211
**FRUTTI
DI BOSCO**
2x125 gr.



FL28209
**0,1%
FRAGOLA**
2x125 gr.



FL10218
MELA VERDE
2x125 gr.



FL10209
FRAGOLA
2x125 gr.



FL28211
**0,1% FRUTTI
DI BOSCO**
2x125 gr.



FL10214
CEREALI
2x125 gr.



FL10207
ALBICOCCA
2x125 gr.



FL28217
0,1% VANIGLIA
2x125 gr.



FL10224
STRACCIATELLA
2x125 gr.



FL10206
ANANAS
2x125 gr.



FL28201
0,1% CAFFÈ
2x125 gr.



FL10210
CILIEGIA
2x125 gr.



FL10205
BANANA
2x125 gr.



FL28212
0,1% MIRTILLO
2x125 gr.



FL10219
COCCO
2x125 gr.



FL10203
LIMONE
2x125 gr.



FL28232
**0,1% ARANCIA
CAR. ZENZERO**
2x125 gr.



FL10201
CAFFÈ
2x125 gr.



FL27212
**SAPORI MIRTILLO
NERO**
2x125 gr.



FL28234
0,1% CARMELLO
2x125 gr.



FL10650
INTERO
5 kg.



FL10416
AGRUMI
500 gr.



FL10401
CAFFÈ
500 gr.



FL10651
MAGRO
5 kg.



FL10403
LIMONE
500 gr.



FL10409
FRAGOLA
500 gr.



FL10410
CILIEGIA
500 gr.



FL10411
**FRUTTI
DI BOSCO**
500 gr.



FL10412
MIRTILLO
500 gr.



FL10417
VANIGLIA
500 gr.



FL10424
STRACCIATELLA
500 gr.



FL10456
FIOR DI LATTE
500 gr.



FL10450
**INTERO
MAGRO**
500 gr.



FL10451
MAGRO
500 gr.



FL19450
NATURALE S/L
500 gr.



FL55808
**BIOLOGICO
LAMPONE**
170 gr.



FL55819
**BIOLOGICO
COCCO
MANDORLE**
170 gr.



FL55827
**BIOLOGICO
MANGO
CURCUMA**
170 gr.



FL36650
**FITLINE DRINK
BIANCO**
6x90 gr.



FL36609
**FITLINE DRINK
FRAGOLA**
6x90 gr.



FL36616
**FITLINE DRINK
MULTIFRUTTI**
6x90 gr.



FL40020
BURRO VIPITENO
250 gr.



FL40123
BURRO VIPITENO PORZIONATO
10 x 12,5 gr.



FL40040
BURRO VIPITENO
1000 gr.



FL25505
**BIO IN VETRO
BANANA**

150 gr.



FL25512
**BIO IN VETRO
MIRTILLO**

150 gr.



FL55908
**BIO IN VETRO
S/L LAMPONE**

150 gr.



FL25509
**BIO IN VETRO
FRAGOLA**

150 gr.



FL25501
**BIO IN VETRO
CAFFÈ**

150 gr.



FL55913
**BIO IN VETRO
S/L NOCCIOLA**

150 gr.



FL25510
**BIO IN VETRO
CILIEGIA/CIOCCO**

150 gr.



FL25502
**BIO IN VETRO
ARANCIA**

150 gr.



FL55934
**BIO IN VETRO
S/L CARAMELLO**

150 gr.



FL25550
**BIO IN VETRO
INTERO**

150 gr.



FL25551
**BIO IN VETRO
MAGRO**

150 gr.



FL25950
**BIO IN VETRO
NATURALE
S.LATTOSIO**

150 gr.



FL25517
**BIO IN VETRO
VANIGLIA**

150 gr.



FL25527
**BIO IN VETRO
MANGO
VANIGLIA**

150 gr.



FL30121
**ALPENYOGURT
MIELE VETRO**

150 gr.



FL30103
**ALPENYOGURT
LIMONE VETRO**

150 gr.



FL30111
**ALPENYOGURT
FR. BOSCO VETRO**

150 gr.



FL26007
**DELLE ALPI
ALBICOCCA**

125 gr.



FL26005
**DELLE ALPI
BANANA**

125 gr.



FL26001
**DELLE ALPI
CAFFÈ**

125 gr.



FL26009
**DELLE ALPI
FRAGOLA**

125 gr.



FL26017
**DELLE ALPI
VANIGLIA**

125 gr.



FL26050
**DELLE ALPI
NATURALE**

125 gr.



FL26011
**DELLE ALPI
FR. BOSCO**

125 gr.

LUNGA CONSERVAZIONE



SUCCHI E UHT

La nostra gamma di succhi (da concentrato) e bevande si caratterizza per i sapori intensi e ben bilanciati in grado di stupire il palato dei consumatori più esigenti. Il risultato di un'attenta ricerca che esprime pienamente l'impegno della nostra produzione.





FL1014024
ARANCIA NET BRICK
3x200 ml.



FL1017024
ALBICOCCA NET BRICK
3x200 ml.



FL1021024
A.C.E. NETT. BRICK
3x200 ml.



FL1045024
ARANCIA ROSSA BRICK
3x200 ml.



FL1018024
PERA NETT. BRICK
3x200 ml.



FL1019024
PESCA NETT. BRICK
3x200 ml.



FL1024024
TROPICALE BRICK
3x200 ml.



FL1020024
MELA NETT. BRICK
3x200 ml.



FL1054024
THE PESCA BRICK
3x200 ml.



FL1013024
THE LIMONE BRICK
3x200 ml.



FL1022015
SUCCO 100% ANANAS
square 1 l.



FL1021015
BEVANDA GUSTO ACE
square 1 l.



FL1045015
SUCCO ARANCIA ROSSA
square 1 l.



FL1019015
SUCCO E POLPA PESCA
square 1 l.



FL1024015
SUCCO 100% TROPICALE
square 1 l.



FL1014015
SUCCO 100% ARANCIA
square 1 l.



FL1015015
SUCCO 100% POMPELMO
square 1 l.



FL1017015
SUCCO E POLPA ALBICOCCA
square 1 l.



FL1020015
SUCCO E POLPA MELA
square 1 l.



FL1018015
SUCCO E POLPA PERA
square 1 l.



FL1001015
LATTE INTERO MICR UHT
square 1 l.



FL1172015
LATTE MICROF. P.S. UHT
square 1 l.



FL1002082
LATTE P.S. BRIK UHT
500 ml.



FL1008004
MASCARPONE
500 gr.



FL1288025
MASCARPONE S/LATTOSIO
250 gr.



FL3007
BESCIAMELLA BRICK
500 ml.



FL2898
PANNA DA CUCINA SORESINA
200 ml.



FL1007061
PANNA DA CUCINA S/LATT.
200 gr.



FL1090025
RICOTTA
500 gr.



FL1025024
BUDINO CIOCCOLATO
220 gr.



FL1026024
BUDINO VANIGLIA
220 gr.



FL1027024
BUDINO CAMELLO
220 gr.



FL1084024
PANNA COTTA CIOCCOLATO
180 gr.



FL1063024
PANNA COTTA CAMELLO
180 gr.



SURGELATI

Carne CARNE

Prodotti surgelati per food service e negozi, sani e genuini, gustosi e di veloce preparazione.

Pensati per soddisfare le esigenze di velocità, praticità, ottimizzazione del food cost e risparmio sullo spreco alimentare dei professionisti della ristorazione, catering e ristorazione veloce o confezionati porzionati per uso domestico, in versione cofanetto, busta o skin.





780217
HAMBURGER DI BOVINO

320 gr. | 5 pz.



200070
HAMBURGER CRUDO

100 gr. | 30 pz.



200068
HAMBURGER CRUDO GRANDE

150 gr. | 40 pz.



200125
MACINATO DI MANZO

400 gr. | 10 pz.



780212
FETTINE DI VITELLO

300 gr. | 10 pz.



780211
MILANESI DI VITELLO IMPANATE

320 gr. | 5 pz.



200160
TRIPPA COTTA

600 gr. | 10 pz.



200165
TRIPPA TAGLIATA CRUDA

1000 gr.



200096
NUGGETS BOCCONCINI FAMILY

540 gr. | 6 pz.



200097
COTOLETTE SPINACI FAMILY

540 gr. | 6 pz.



200098
CORDON BLEU FAMILY

540 gr. | 6 pz.



200099
COTOLETTE FAMILY

540 gr. | 6 pz.



SA995282
SPEEDY POLLO ORIGINAL

300 gr. | 12 pz.



SA295055
SPEEDY POLLO ALETTE MEXICO

3000 gr. | 6 pz.



SA73126
GIGA COTOLETTA

250 gr. | 8 pz.



NF8978
COTOLETTA POLLO

180 gr. | 9 pz.



NF8980
NUGGET

180 gr. | 9 pz.



NF9009
CORDON BLEU

180 gr. | 9 pz.



NF9010
COTOLETTA SPINACI

180 gr. | 9 pz.



NF9011
ALETTE POLLO

180 gr. | 9 pz.



200403
FESA DI TACCHINO PESO VAR.

8 pz. | 3,3 kg. circa



A7574
PETTI DI POLLO

3 kg.



200404
COSCE DI POLLO PESO VAR.

6 pz. | 3,0 kg. circa



1/130
POLLO EVISCERATI

vendita al kg.



1/126
POLLO COSCE

vendita al kg.



1/135
POLLO PETTI

vendita al kg.



1/90
CONIGLIO

vendita al kg.



1/105
FESA DI TACCHINO

vendita al kg.



1/106
TACCHINO ROTOLI FESA

vendita al kg.



1/115
LONZA SUINO

vendita al kg.

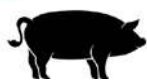

1/116
STINCO SUINO INTERO

vendita al kg.



1/117
STINCO SUINO MEZZO

vendita al kg.



1/88
LEPRE POLPA

5 kg.



1/85
CERVO POLPA EXTRA

5 kg.



1/86
CAPRIOLO POLPA EXTRA

5 kg.



1/87
CINGHIALE POLPA EXTRA

5 kg.



1/70
AGNELLO INTERO

vendita al kg.



1/71
AGNELLO COSTOLETTE

vendita al kg.



SURGELATI

Pesce
PESCE

Prodotti ittici surgelati per food service e negozi, sani e genuini, gustosi e di veloce preparazione. Pensati per soddisfare le esigenze di velocità, praticità, ottimizzazione del food cost e risparmio sullo spreco alimentare dei professionisti della ristorazione, catering e ristorazione veloce o confezionati porzionati per uso domestico, in versione cofanetto, busta o skin.





780201
FILETTI DI PLATESSA AL NAT.
300 gr. | 10 pz.



780202
FILETTI DI PLATESSA IMPANATA
300 gr. | 9 pz.



80151
FIL. DI PLATESSA ALLA MUGNAIA
250 gr.



80103
FILETTI DI PLATESSA IN BUSTA
400 gr.



1/217
FILETTI DI PLATESSA
vendita al kg.



2/288
PLATESSA IMPANATA
vendita al kg.



80157
FILETTI DI MERLUZZO PANATO
400 gr. | 8 pz.

80118
BASTONCINI DI MERLUZZO
300 gr. | 10 pz.



80101
FILETTI DI MERLUZZO IN BUSTA
400 gr.



1/215
FILETTI DI NASELLO
vendita al kg.



1/216
MERLUZZO FIORI
vendita al kg.



1/158
MERLUZZO DECAPITATO 800/1200
vendita al kg.



AR1402
FILETTI DI ALICI PANATI
180 gr.



1/199
COTOLETTE DI PESCE
vendita al kg.



1/175
BASTONCINI DI PESCE PANATI
vendita al kg.



1/231
FILETTI DI PANGASIO
vendita al kg.



780101
FILETTI DI ORATA
250 gr.



80113
FILETTI DI ORATA IN BUSTA
400 gr.



1/194
FILETTI DI ORATA 80/120
vendita al kg.



1/139
ORATA EVISCERATA
vendita al kg.



780102
FILETTI DI BRANZINO
250 gr.



80112
FILETTI DI BRANZINO IN BUSTA
400 gr.



1/185
FILETTI DI BRANZINO
vendita al kg.



780266
TRANCE DI VERDESCA IN BUSTA
400 gr.



1/260
VERDESCA PORZIONATA
vendita al kg.



780260
FILETTI DI SCORFANO IN BUSTA
400 gr.



780263
SPADA IN BUSTA
400 gr.



1/362
SPADA A FETTE
vendita al kg.



80104
FILETTI DI CERNIA BUSTA
400 gr.



80128
FILETTI DI PASSERA BUSTA
400 gr.



780135
FILETTI DI TONNO
250 gr.



1/155
TONNO PINNE GIALLE A FETTE
vendita al kg.



1/230
FILETTI DI HALIBUT
vendita al kg.



780140
FILETTI DI TROTA SALMONATA
250 gr.



1/213
FILETTI DI TROTA SALMONATA
vendita al kg.



1/212
FILETTI DI TROTA BIANCA
vendita al kg.



780262
FILETTO PORZ. DI SALMONE
250 gr.. circa



1/315
SALMONE TRANCIO
vendita al kg.



1/365
SPIEDINI DI PESCE
vendita al kg.



AR1401
TRIS BOCCONCINI DI MARE
200 gr.



1/180
BASTONCINI POLPA DI GRANCHIO
vendita al kg.



1/200
CHELE DI GRANCHIO
vendita al kg.



80044
ANELLI DI TOTANO CROCCANTI
250 gr. | 10 pz.



80043
FRITTO MISTO DI PESCE DA FORNO
450 gr. | 10 pz.



1/160
ACQUADELLE
vendita al kg.



80020 • 80023
ANELLI ALLA ROMANA PASTELLATI
500 gr. | 10 pz. • 1000 gr. | 5 pz.



1/167
ANELLI TOTANO FRIOPEPE
vendita al kg.



1/164 • AR10450
CALAMARI CIUFFI I.Q.F.
vendita al kg. | 4,25 kg.



80042
ZUPPA DI PESCE COTTA
500 gr. | 12 pz.



1/161
ZUPPA DI PESCE
vendita al kg.



1/178
ANTIPASTO DI MARE COTTO
vendita al kg.



1/375 • 1/380 • 1/346
TUBI CALAMARI U10 • U5 • 11/20
vendita al kg.



1/201
MOSCARDINI
vendita al kg.



780090
SEPPIE PULITE BUSTA
400 gr.



1/345 • 1/350 • 1/355
SEPPIE 60UP • 20/40 • 500/1000
vendita al kg.



1/275 • 1/276 • 1/281
PIOVRA 500/1000G • 1/2KG • OLTRE 2KG
vendita al kg.



80015
POLPO CON PATATE
500 gr. | 6 pz.



780138
INSALATA DI MARE COTTA IN BUSTA
360 gr.



1/162
PREPARATO PER SCOGLIO
vendita al kg.



1/193 • 1/188 • 1/192 • 1/187
CODE DI GAMBERO
26/30 • 30/40 • 41/50 • 51/60
vendita al kg.



1/396
VANNAMEI SGUSCIATI CRUDI 31/40
vendita al kg.



1/246 • 1/247
GAMBERI L1 10/20 • L2 20/30
vendita al kg.



1/244
GAMBERI SGUSCIATI LESSI 80/120
vendita al kg.



780103
GAMBERETTI SGUSCIATI PREC. BUSTA
400 gr.



1/335 • 1/202
SCAMPONI 8/12 • 13/16
vendita al kg.



80370
PREPARATO PER RISOTTO SKIN
300 gr.



80374
SPAGHETTATA DI MARE SKIN
300 gr.



AR5009
GAMBERI SGUSCIATI SKIN
200 gr.



1/196
COZZE CON GUSCIO
vendita al kg.



1/195
COZZE SGUSCIATE
vendita al kg.



AR5016
COZZE SGUSCIATE SKIN
250 gr.



780286
VONGOLE S/GUSCIO MATTONELLA
250 gr.



1/490
VONGOLE S/GUSCIO
vendita al kg.



1/395
VONGOLE CON GUSCIO
vendita al kg.



AR7007
CONDIVONGOLA
450 gr.



AR7002
CONDISCOGLIO AL POMODORO
450 gr.



AR7001
CONDISCOGLIO
450 gr.



AR7006
CONDISCAMPI
300 gr.



AR5069
MARE ORTO SKIN ASTUCCIATO
300 gr.



AR 5105
MISTO RISOTTO ASTUCCIATO
300 gr.



80038 • 80047
PAELLA
500 gr. | 6 pz. • 1250 gr. | 4 pz.



80041
MEZZEMANICHE AI FRUTTI DI MARE
550 gr.



80045
RAVIOLI RICOTTA E SPINACIV
550 gr.



80033
SPAGHETTI ALLE VONGOLE
550 gr.



80034
PENNETTE SALMONE E GAMB.
600 gr.



80036
TAGLIATELLE AI FUNGHI
550 gr.



80037
LINGUINE ALLO SCOGLIO
550 gr.



80039
SPAGHETTI ALLA CARBONARA
550 gr.



80040
BUCATINI ALL'AMATRICIANA
550 gr.

SFIZIOSI



780281
TENERELLI FORMAGGIO
250 gr.



780282
TENERELLI PIZZAIOLA
250 gr.



780283
TENERELLI PROSC/FORMAGGIO
250 gr.



780284
MOZZARELLINE IMPANATE
250 gr.



780285
OLIVE ALL'ASCOLANA
250 gr.

PASTA GIALLA LASAGNE E SFOGLIA

200040
PASTA GIALLA LASAGNE
500 gr. | 12 pz.



1000145
PASTA GIALLA LASAGNE
2 Kg. | 5 pz.



200179
PASTA SFOGLIA ROTOLO
500 gr. | 10 pz.

1000148
PASTA SFOGLIA LAMINATA
1 kg. | 10 pz.



1000150
PASTA SFOGLIA
1 kg. | 4 pz.





SURGELATI

Verdure VERDURE

Oggi, per conquistare e fidelizzare il Cliente, è indispensabile fornire un prodotto di qualità, e qualità significa più selezione, più controlli, massima attenzione nella conservazione e nella puntualità dei servizi logistici. Fondamentale è soddisfare tutte le richieste di una clientela attenta ed esigente, proponendo una completa selezione di verdure surgelate di grande gusto e sapore.





003A
BROCCOLI

1 kg.



780010
BROCCOLI

450 gr. | 8 pz.



780015
ASPARAGI

300 gr. | 12 pz.



001
ASPARAGI

1 kg.



005A
CARCIOFI

1 kg.



780020
CAROTINE INTERE

400 gr. | 8 pz.



015A
CAROTINE INTERE

2,5 kg.



010A
CAROTE DISCO

2,5 kg.



780002
CIME DI RAPA

450 gr. | 8 pz.



020A
CAVOLFIORI

2,5 kg.



040A
FINOCCHI

2,5 kg.



780028
CIPOLLE BORETTANE

450 gr. | 8 pz.



780023
CONTORNO DEL CAMPO

450 gr. | 8 pz.



780011
PEPERONATA

450 gr. | 8 pz.



780014
COSTA BIETA CUBETTI

450 gr. | 8 pz.



025A
COSTA BIETA CUBETTI

2,5 kg.



780022
BIETE COSTA BIANCA FOGLIA

450 gr. | 8 pz.



780004
FAGIOLINI FINISSIMI
450 gr. | 8 pz. • 1000 gr. | 10 pz.



030A
FAGIOLINI FINISSIMI
2,5 kg.



780008
FAGIOLI BORLOTTI
450 gr. | 8 pz.



035A
FAGIOLI BORLOTTI
2,5 kg.



780026
INSALATA RUSSA
450 gr. | 8 pz.



060A
INSALATA RUSSA
1 kg.



780003 / 017 / 007
MINISTRONE
450 gr. | 8 pz. • 600 gr. | 8 pz • 1 kg. | 10 pz.



065A
MINISTRONE
2,5 kg



071A
MISTO PER SOFFRITTO
1 Kg.



780009
PREZZEMOLO TRITATO
50 gr. | 12 pz.



780024
BASILICO TRITATO
50 gr. | 12 pz.



780005
MISTO PER SOFFRITTO
150 gr. | 12 pz.



780016
CIPOLLA TRITATA
150 gr. | 12 pz.



780000
PISELLI FINI
450 gr. | 8 pz. • 1000 gr. | 10 pz.



1/16A
SPINACI CUBO
2,5 kg



780018
PISELLI FINISSIMI
450 gr. | 8 pz.

780001
SPINACI IN FOGLIA
450 gr. | 8 pz.



780035
PISELLI PROSCIUTTO E FORMAGGIO
400 gr. | 8 pz.



780006
SPINACI CUBO
1000 gr. | 10 pz. • 450 gr. | 12 pz.





780027
MELANZANE GRIGLIATE A FETTE
450 gr.



780012
ZUCCHINE A DISCO
450 gr. | 8 pz. • 600 gr. | 8 pz.



1/20A
ZUCCHINE DISCO
2,5 kg.



2/210
ZUCCHINE GRIGLIATE
1 Kg. | 2 pz.



2/200
MELANZANE GRIGLIATE
1 Kg. | 2 pz.



2/205
PEPERONI GRIGLIATI
1 Kg. | 2 pz.



780033
VERZA A PEZZETTONI
450 gr. | 8 pz.



1/10A
PISELLI MEDI
2,5 kg



070
MISTO BOSCO
1000 gr.

Funghi

FUNGHI



1/5019A • 1/5020A • 1/5070A
FUNGHI PORCINI INTERI
Prima • Medi • Seconda 1 kg.



1/5201A
FUNGHI MISTI EXTRA 7 GUSTI
1 kg.



1/5206A
FUNGHI CUBO
1 kg.



1/5221A
FUNGHI CHAMPIGNON
1 kg.



Patate e Fritti

PATATE E FRITTI



1/1000
PATATE FRITTE 10X10MM
2,5 kg. | 4 pz.



1/1002
PATATE JULIENNE
2,5 kg. | 4 pz.



1/1004
PATATE BRAVAS
2,5 kg. | 2 pz.



1/2000
PATATE DIPPERS
2,5 kg. | 4 pz.



1/5
PATATE PREFRITTE
2,5 kg. | 5 pz. **ANCHE IN FORNO**



1/6
PATATE SPICY
2,5 kg. | 4 pz.



1/7
PATATE STEAK HOUSE
2,5 kg. | 5 pz.



085
PATATE SPICCHIO
2,5 kg. | 4 pz.



088
FRY'N DIP
2,5 kg. | 5 pz.



100
PATATE CROCCHETTE
2,5 kg. | 4 pz.



1/55A
VERDURE PASTELLATE
1 kg. | 4 pz.



1/56A
ZUCCHINE PASTELLATE
1 kg. | 4 pz.



078
OLIVE ASCOLANE
2 kg. | 3 pz.



079
MOZZARELLINE PANATE
2 kg. | 3 pz.



200050
PATASNELLA

1000 gr. | 10 pz. **ANCHE IN FORNO**



200071
SPICCHI GUSTOSI PATASNELLA

750 gr. | 12 pz. **ANCHE IN FORNO**



200094
CASALINGHE PATASNELLA

600 gr. | 10 pz. **ANCHE IN FORNO**



200078
CROCCHETTE PATASNELLA

750 gr. | 10 pz. **ANCHE IN FORNO**



200096
FRITTE EXTRAFINI

600 gr. | 10 pz.



200076
BARCHETTE PATASNELLA

600 gr. | 12 pz. **ANCHE IN FORNO**



200081
TOCCHETTI PATASNELLA

600 gr. | 10 pz. **ANCHE IN FORNO**



200072
PATATE FRITTE

1000 gr. | 10 pz.



200093
"WE LOVE" RUSTICHE

750 gr. | 10 pz.



200082
"WE LOVE" GUSTOSE RUSTICOSE

600 gr. | 8 pz.



200075
PATATE SPICCHI

1000 gr. | 10 pz.



200095
FORMINE TOPOLINO CROCCOMAGIE

600 gr. | 12 pz.



200083
FIAMMIFERI CROCCANTIXIMI

600 gr. | 12 pz.



200085
PATATE MR. ZIGHI

600 gr. | 8 pz.



200090
PATATE NOVELLE

1000 gr. | 10 pz.



200074
"WE LOVE" CROCCANTI

450 gr. | 10 pz.

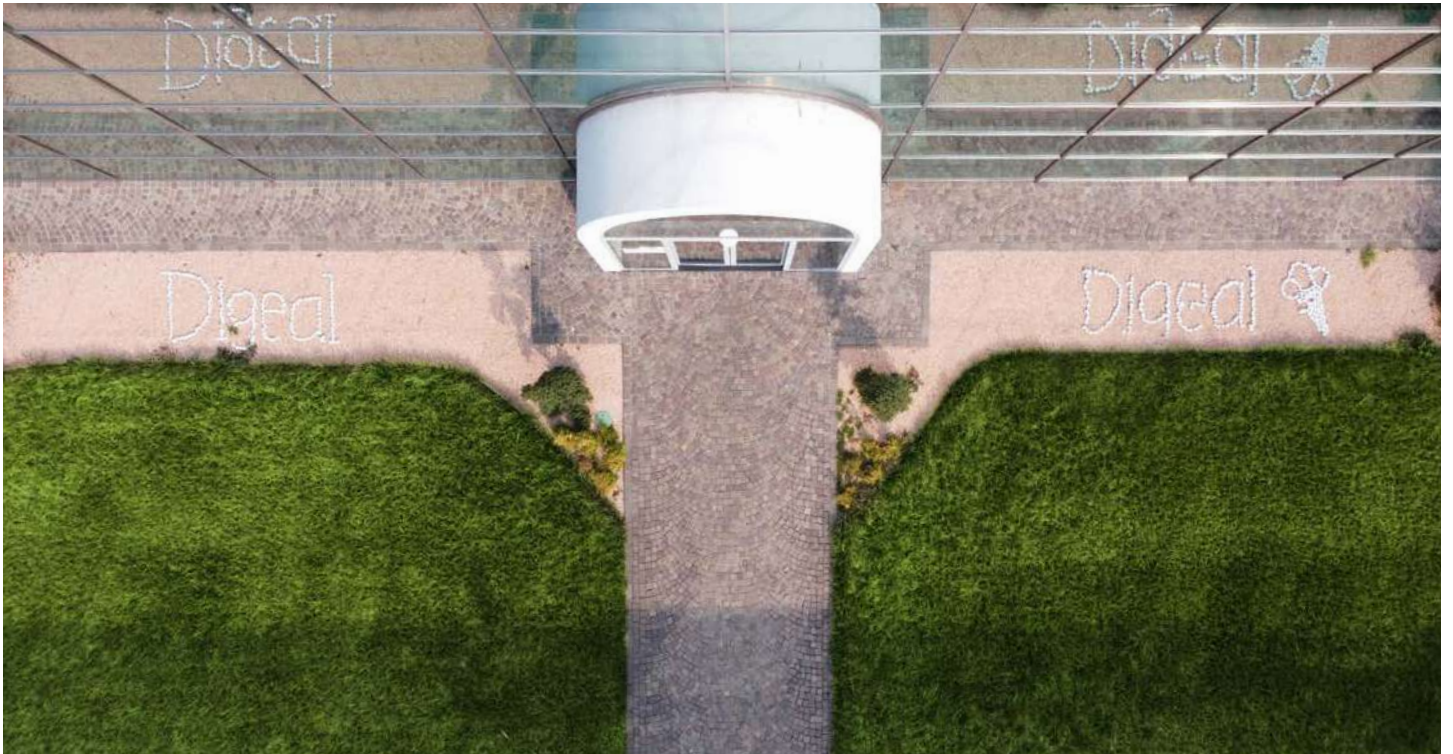

FINITO DI STAMPARE IL 15/11/2024

**TUTTE LE IMMAGINI SONO INSERITE A SCOPO ILLUSTRATIVO.
I PRODOTTI POSSONO SUBIRE MODIFICHE.**

40 *quaranta*



www.digeal.it | Via Crema 4C, Zanica | Tel. 035 671888